

GEOHERMAL DISTRICT PIPING - A PRIMER

Kevin Rafferty

November, 1989

Abstract

Transmission and distribution piping constitutes approximately 40 - 60% of the capital costs of typical geothermal district heating systems. Selection of economical piping suitable for the fluid chemistry is critical. Presently, most piping (56%) in geothermal systems is of asbestos cement construction. Some fiberglass (19%) and steel (19%) is also in use. Identification of an economical material to replace asbestos cement is important to future project development. By providing information on relative costs, purchase considerations, existing material performance and new products, this report seeks to provide a background of information to the potential pipe purchaser. A brief discussion of the use of uninsulated piping in geothermal district heating systems is also provided.

TABLE OF CONTENTS

Abstract	i
Table of Contents.	ii
Introduction	1
Piping Currently In Use	2 - 11
Designer/Operator Preference	12 - 21
Performance of Existing Piping	22 - 25
Piping Cost	26 - 30
Uninsulated Piping	31 - 36
Items Important to the Consideration	
Of Uninsulated Piping	37 - 39
Considerations in the Application	
Of Various Piping Materials	40 - 43
References	44
Appendix	46 - 49

GEOTHERMAL DISTRICT PIPING - A PRIMER

Kevin Rafferty

November, 1989

Introduction

Transmission and distribution piping can constitute a significant cost component in a geothermal system. For district heating systems, the cost associated with the distribution network is frequently 40 - 60% of the overall capital cost of the project. For this reason, it is important to select the least cost material which is suitable for the application. The information contained in this report is intended to provide a background for the selection of piping for direct buried service in low temperature (<250°F) geothermal systems.

In addition to the cost considerations discussed above, some recent confusion has arisen among system operators as to which material to use. Historically, most piping (~55%) in these system was of asbestos cement construction. This material was very successful in terms of installed cost and chemical compatibility with the fluids. Unfortunately, concern regarding the health related aspects of asbestos cement products has rendered this product unusable from a practical standpoint. As a result, it is important to identify

cost effective alternative piping materials for future project construction.

Finally, several new products have recently become available. The suitability of and cost associated with these products should be evaluated for geothermal application.

This report address only pre-insulated and bare piping products of 2" and larger, nominal size. Included are sections on existing installed piping by type, operator/designer preference with regard to material, performance of existing installed piping cost considerations, and insulated vs. uninsulated piping.

Piping Currently in Use

The following data was taken from a recent survey (Rafferty, 1989) of 13 operating geothermal district heating systems. The total main line (>2") piping included in the systems reviewed for that report amounted to approximately 260,000 lf.

Figure 1 provides a breakdown of the total piping by type. As indicated, asbestos cement (AC) material is clearly the most widely applied product with approximately 55% of the total piping in these systems. Steel and fiberglass are a distant second to AC. Only minimum quantities of polybutylene, ductile iron and PVC are in use. Of note is the fact that there is increasing interest in ductile iron. Its relatively low cost and simple installation techniques are similar to the now unavailable AC pipe. The PVC currently in use is all uninsulated piping in use on the collection network of one of the low temperature systems.

District heating systems can be designed as "open" or "closed" distribution networks. In the open design, the geothermal fluid is delivered directly to the customer. Waste or cooled fluid is collected in the return piping for delivery to the disposal facility. Closed systems, on the other hand, employ central heat exchangers to isolate most of the district heating system from the geothermal fluid. Heat is delivered to the customer via a "closed loop" of clean treated water.

Existing Installed Piping (> 2") Geothermal District Heating Systems

Figure 1

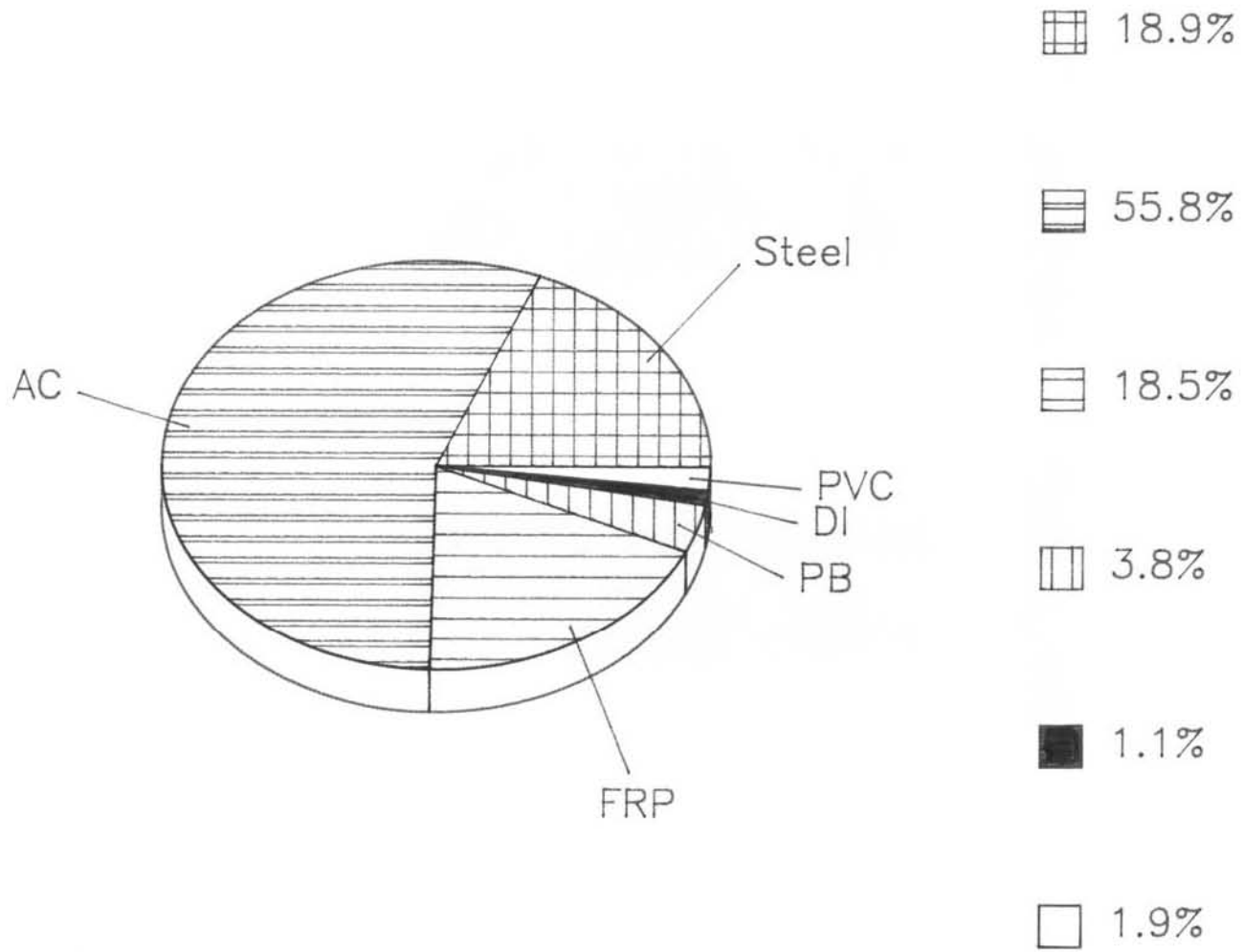

The characteristics of open and closed systems are quite different. For example, closed systems generally employ insulated piping for both the supply and return piping; whereas open systems use insulation only on the supply piping. More importantly, open systems expose all the piping to the geothermal fluids and as a result, corrosion considerations are more critical to these designs. Finally, the cost of closed systems is generally much higher than open systems. This is the result of costs associated with the central plant and the more extensive use of insulated piping.

Figure 2 provides a breakdown of total piping with respect to quantities used in open and closed distribution systems. As indicated, open systems constitute most of the piping applications

For the piping used in the closed distribution systems, Figure 3 provides a breakdown by type. Clearly, steel piping is the choice for this distribution.

Figure 4 provides a similar breakdown for piping used in open systems. Again AC pipe has obviously been the material of choice for applications in which the pipe must be exposed to the geothermal fluid. Asbestos cement far exceeded its closest competitor (FRP~18%) for this application. The previous popularity of AC, coupled with the fact that it is for practical purposes no

Comparison of Total Amount of Pipe Used in Open and Closed Geothermal District Heating

Figure 2

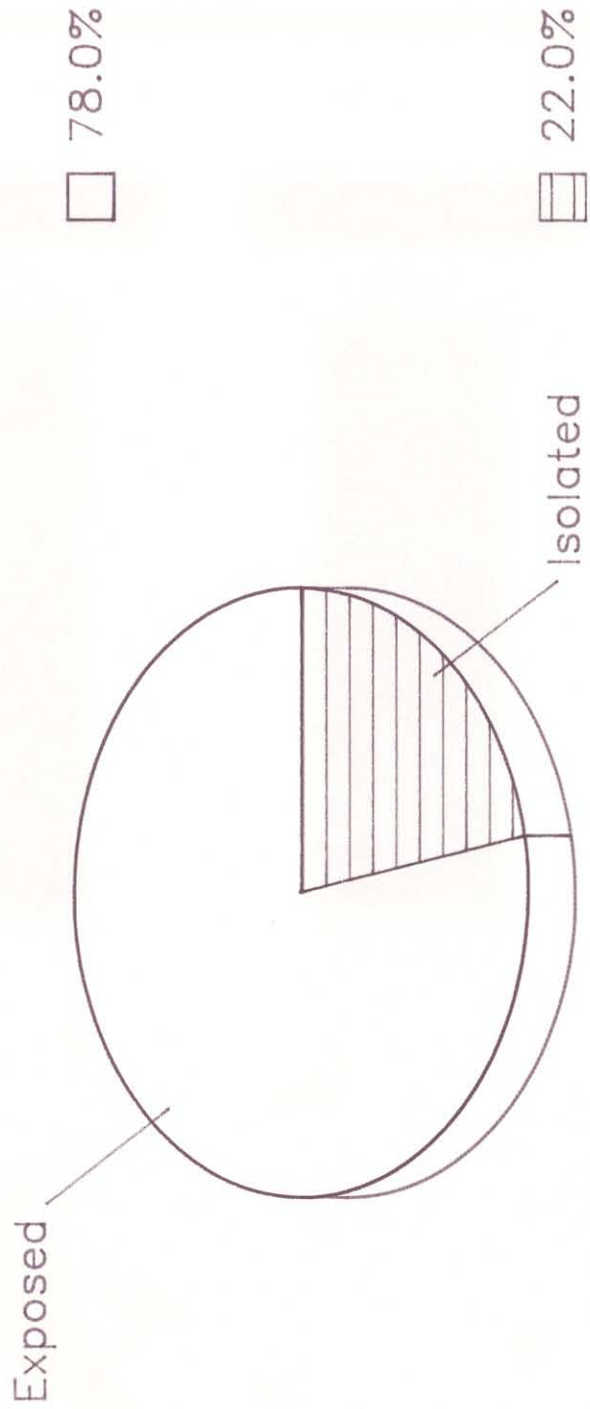

Distribution of Piping Used in Closed Loop Geothermal Systems

Figure 3

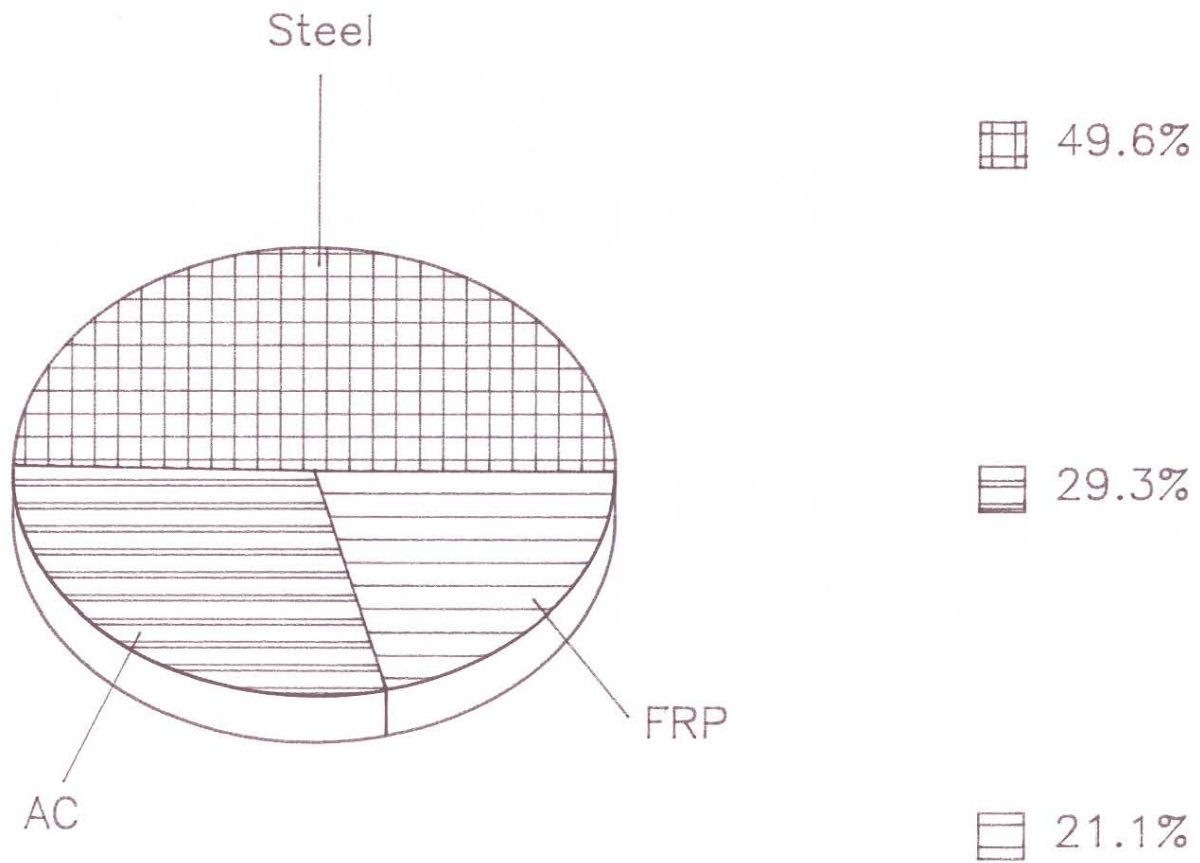

7

Distribution of Pipe Used in Open Geothermal District Heating Systems

Figure 4

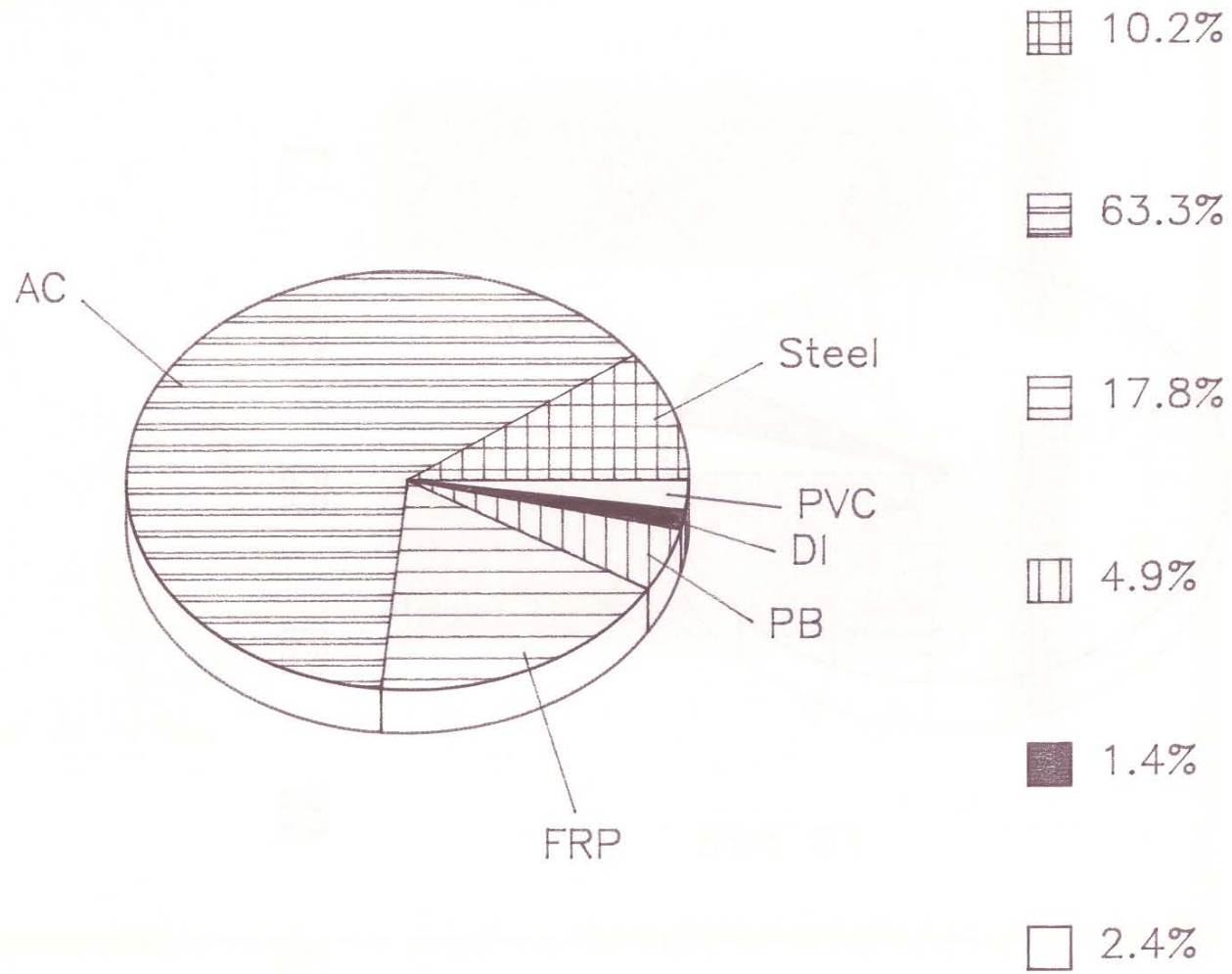

longer available, underscores the need to identify a low cost alternative for the application

None of the geothermal district systems reviewed uses piping larger than 14". A breakdown of piping by size appears in Figure 5.

As discussed above, many of these systems employ uninsulated piping on the return (or disposal) side of the distribution system. As indicated in Figure 6, fully 27% of all distribution piping in these systems is uninsulated. The prospect for increased use of uninsulated material in future systems is discussed later in this report.

Size Distribution of Piping in Geothermal District Heating Systems

Figure 5

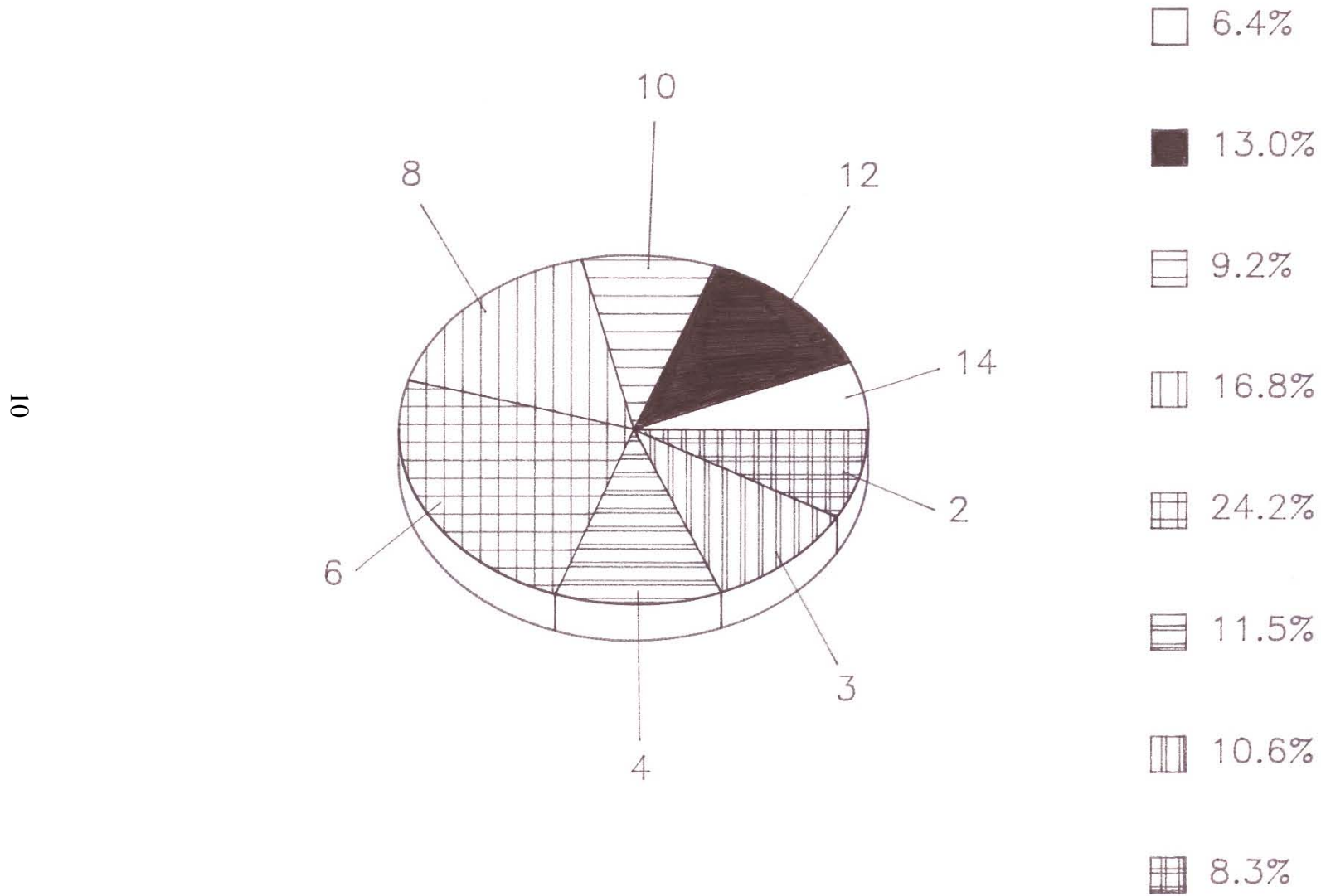

Comparison of Relative Amounts of Insulated and Uninsulated Pipe
in Geothermal District Heating Systems

Figure 6

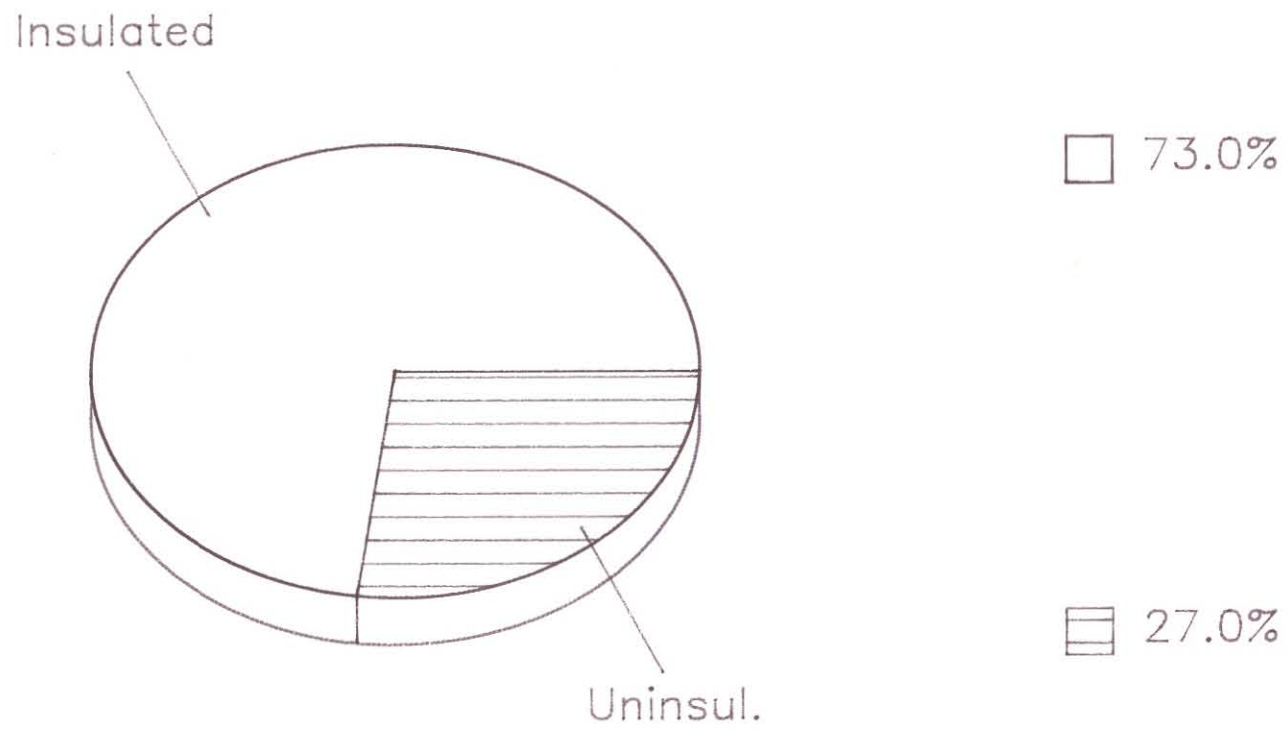

Designer/Operator Preference

An important consideration in the selection of any piece of equipment is the opinion of those who have operating experience with it. Toward that end, a survey was taken of the individuals involved with the design and operation of several geothermal district heating systems.

Respondents were asked to provide preferences for pre-insulated and uninsulated piping under two circumstances. Case I was based upon normal project limitations of time, budget and contractor skill levels. Case II was based on an unlimited budget, that is, cost of the piping and its installation were not to be a factor in the selection. Finally, a preference for jacketing material was requested.

Of the 21 survey sheets sent out, 16 were returned for a 76% response. Although this is a small number, it nevertheless represents a majority of geothermal system operators and designers given the fact that only 18 such systems are in operation in the U.S. All of the respondents are either full-time operators of existing geothermal district heating systems or designers of existing systems.

Figure 7 presents the results of the preference for the pre-insulated supply piping for the system.

Preinsulated Piping Preference - Case I - Survey Results

Figure 7

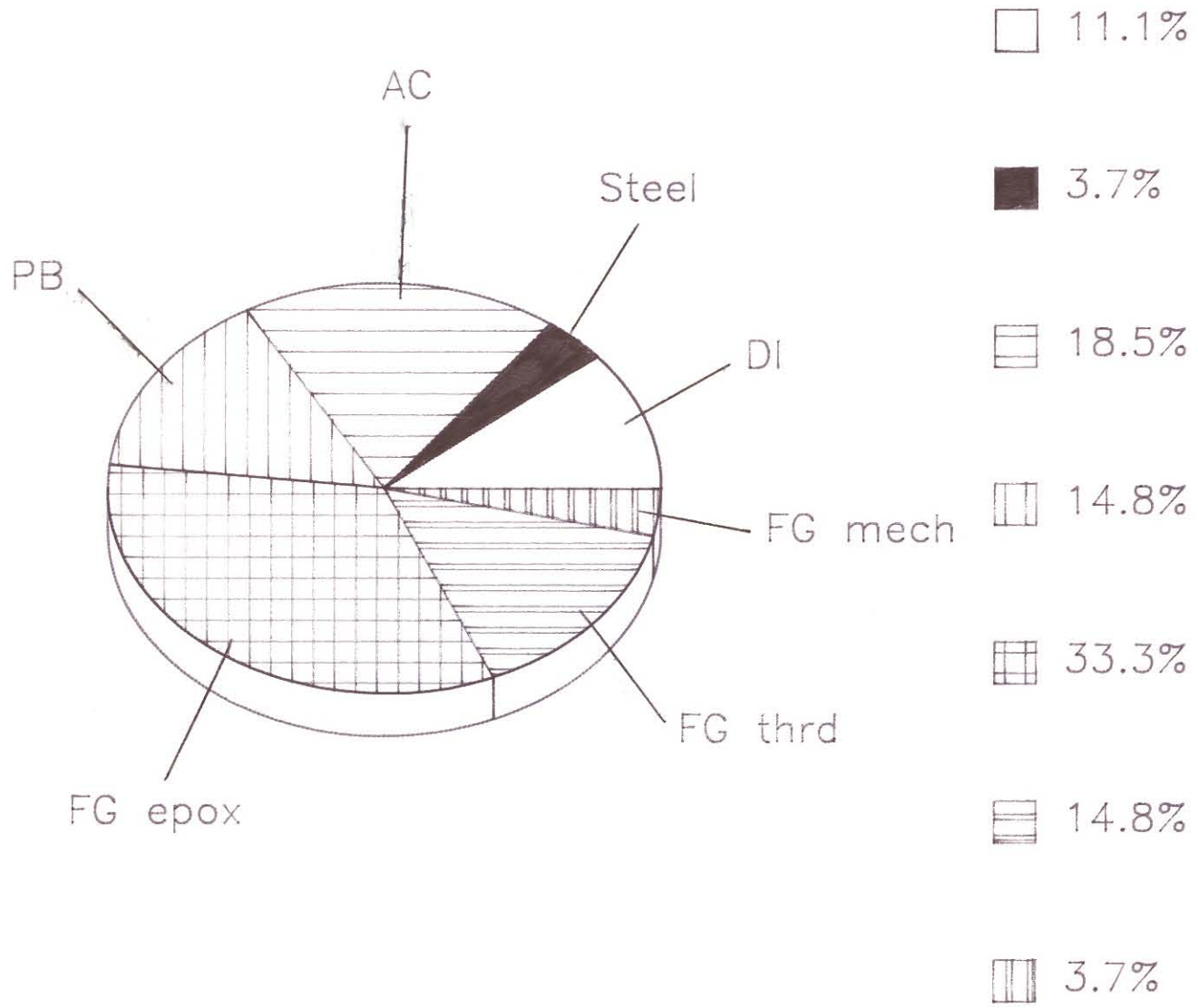

As shown, fiberglass piping with epoxy adhesive connections is the most popular with the group. Despite its lack of availability, asbestos cement remains high on the list as well. Surprisingly, polybutylene is nearly as popular as asbestos cement. At present, only 1 system, Susanville HUD, contains pre-insulated polybutylene piping in the distribution network.

Two products previously unused in geothermal applications also are highlighted: ductile iron and threaded FRP. Ductile iron is currently being used in the San Bernardino Water District system for mainline extensions. Threaded FRP piping has not, to date, been used in any district system. Approximately 2,500 feet of uninsulated 6" material was installed in a transmission line to a greenhouse project in California recently (Dellinger, 1989).

The results of the preference for uninsulated piping appearing in Figure 8, follows the same general trend as those for the pre-insulated pipe with the exception of a slight increase in the interest in threaded and epoxy joint fiberglass. This occurs at the expense of ductile iron and steel piping which may not be competitive in the uninsulated application due to the need to employ exterior protection in many cases.

The second set of responses (Figures 9 and 10) was based on the assumption that the cost of the piping was not to be a factor in the selection. The increase interest in polybutylene from Case I

Bare Pipe Preference - Case I - Survey Results

Figure 8

15

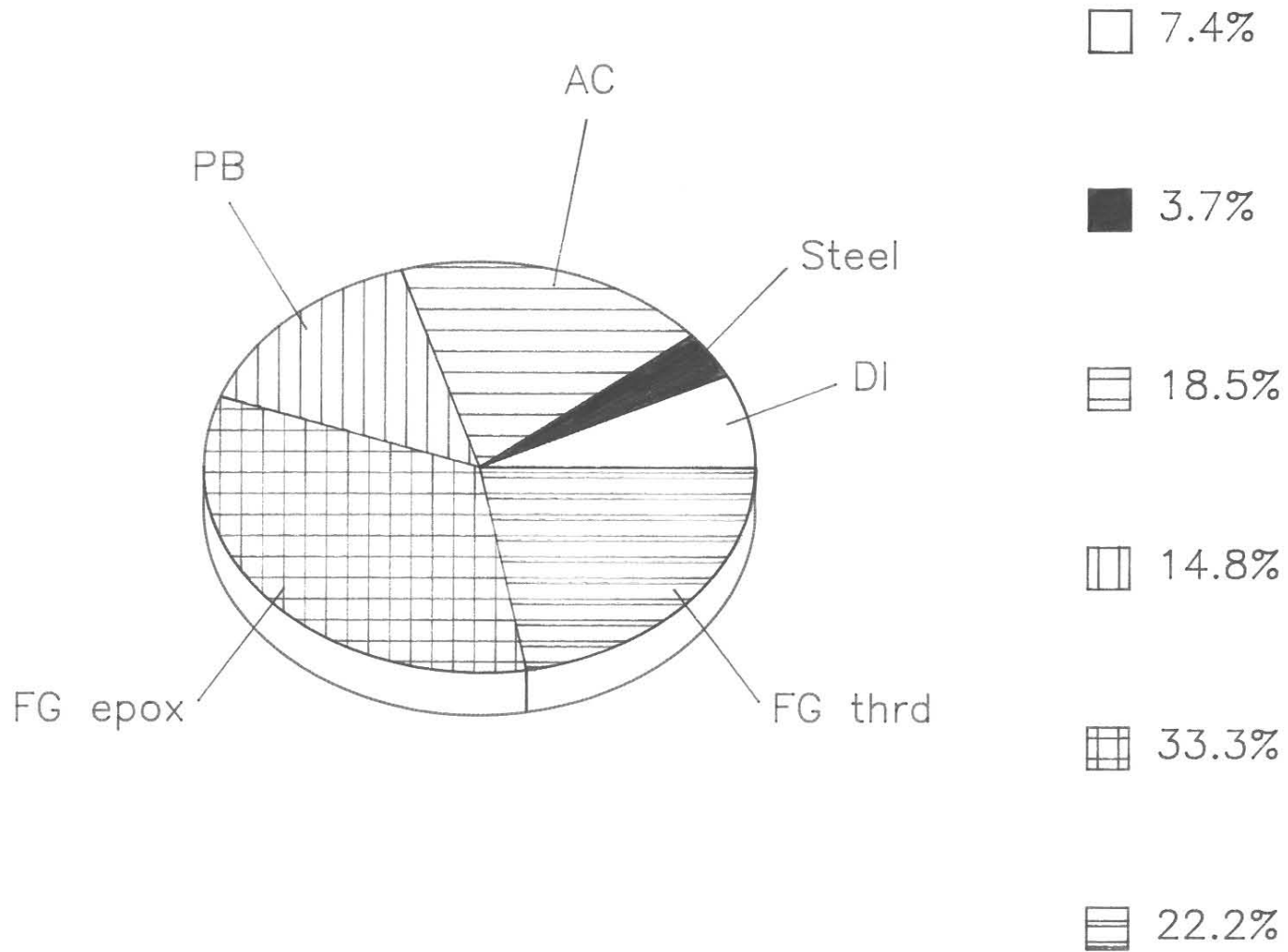

Preinsulated Pipe Preference - Case II - Survey Results

Figure 9

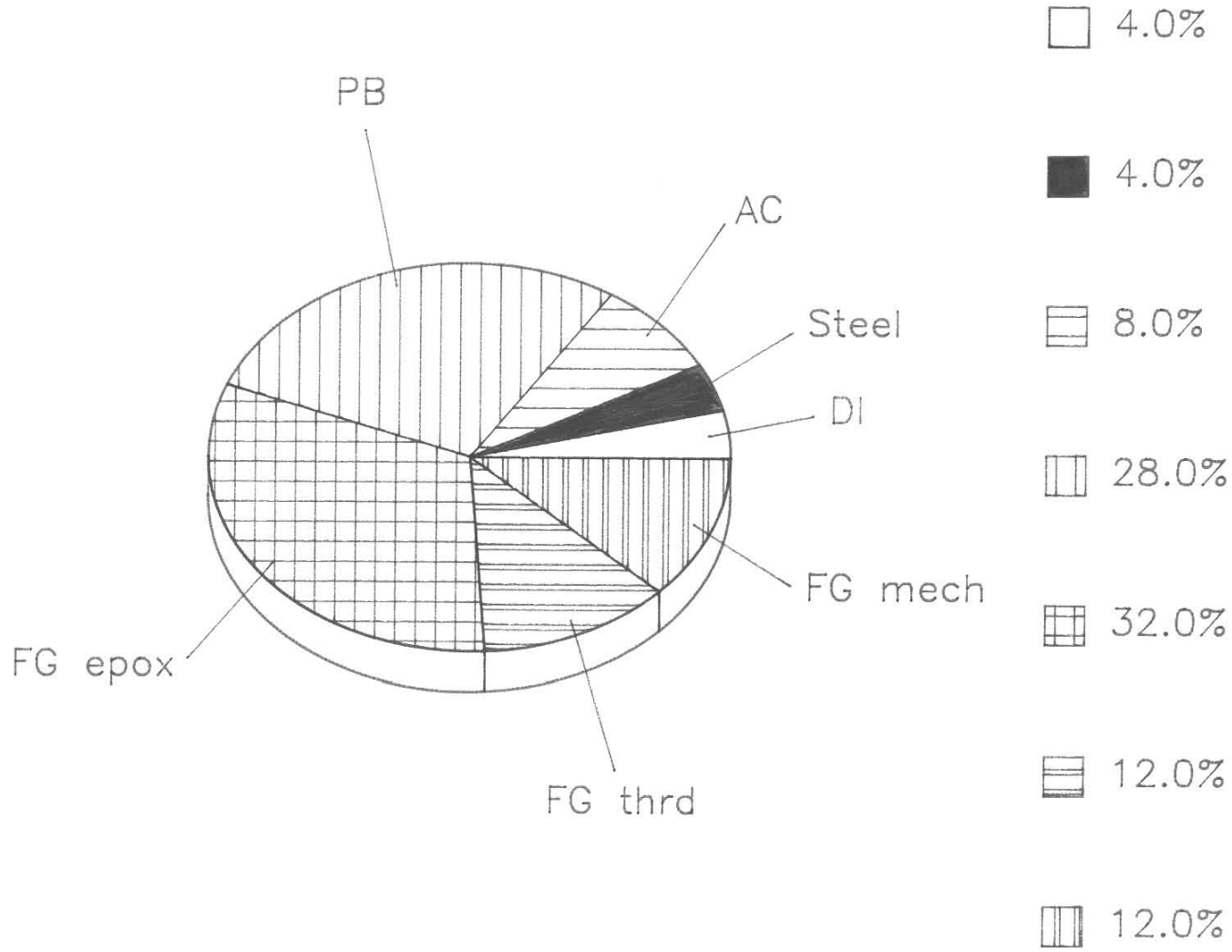

Bare Pipe Preference - Case II - Survey Results

Figure 10

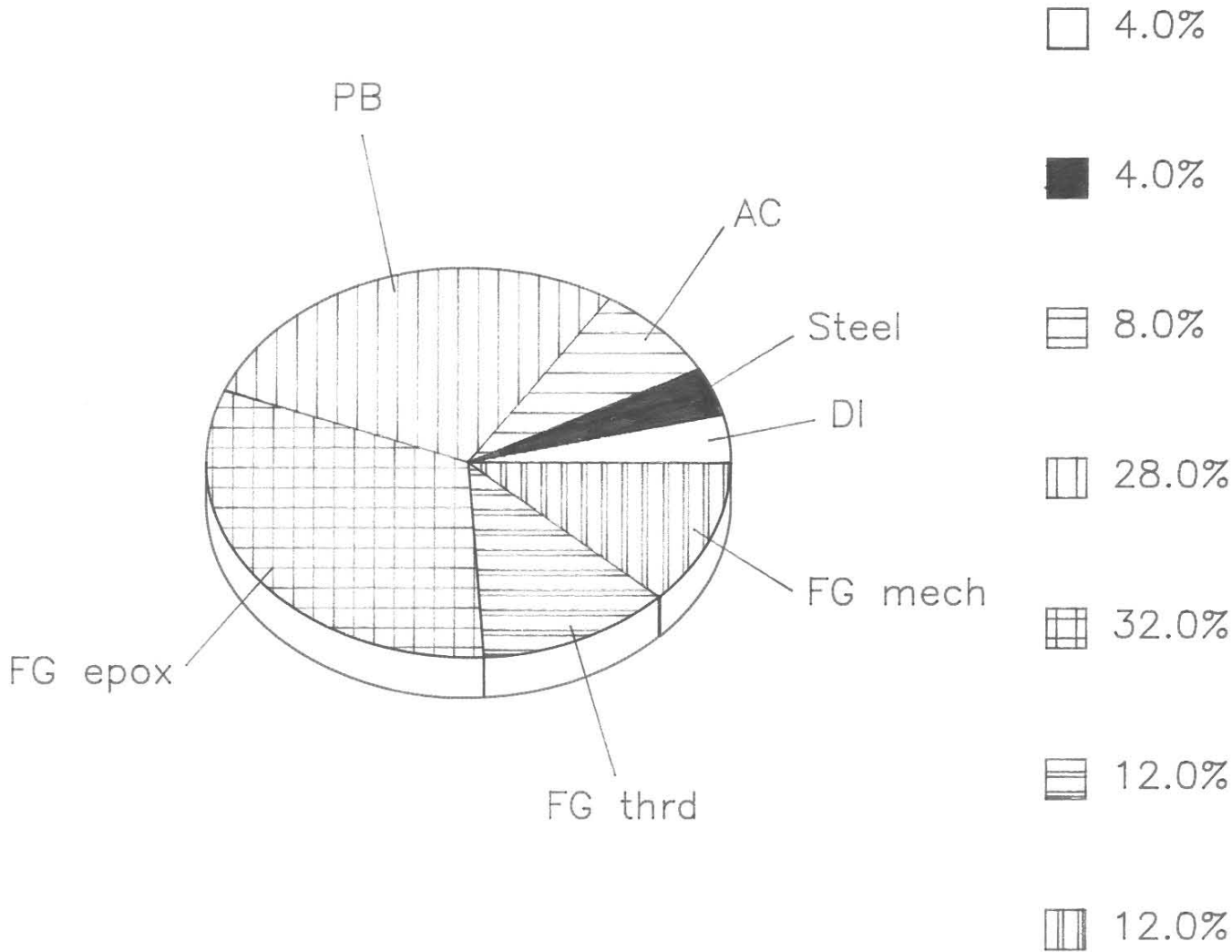

to Case II indicates a perception that this is a high priced product. Bids from vendors, however, do not bear this out. As indicated in Figure 13, polybutylene material is competitive with most other nonmetallic piping products.

Also indicated is a slightly increased interest in mechanical joint fiberglass piping.

Figure 11 presents the results of the jacket material preference for pre-insulated piping. The two least expensive, and currently most common, PVC and PE are the favorites of this group.

It is interesting to compare the results of this survey with the current stock of installed piping. Clearly the interest demonstrated by this group of individuals is in piping other than that which they currently have in their own systems.

Figure 12 compares the current installed piping stock (in percent by type) with the results of the survey of operators and designers. There is a definite shift away from asbestos cement to fiberglass and polybutylene materials.

Jacket Material Preference - Survey Results

Figure 11

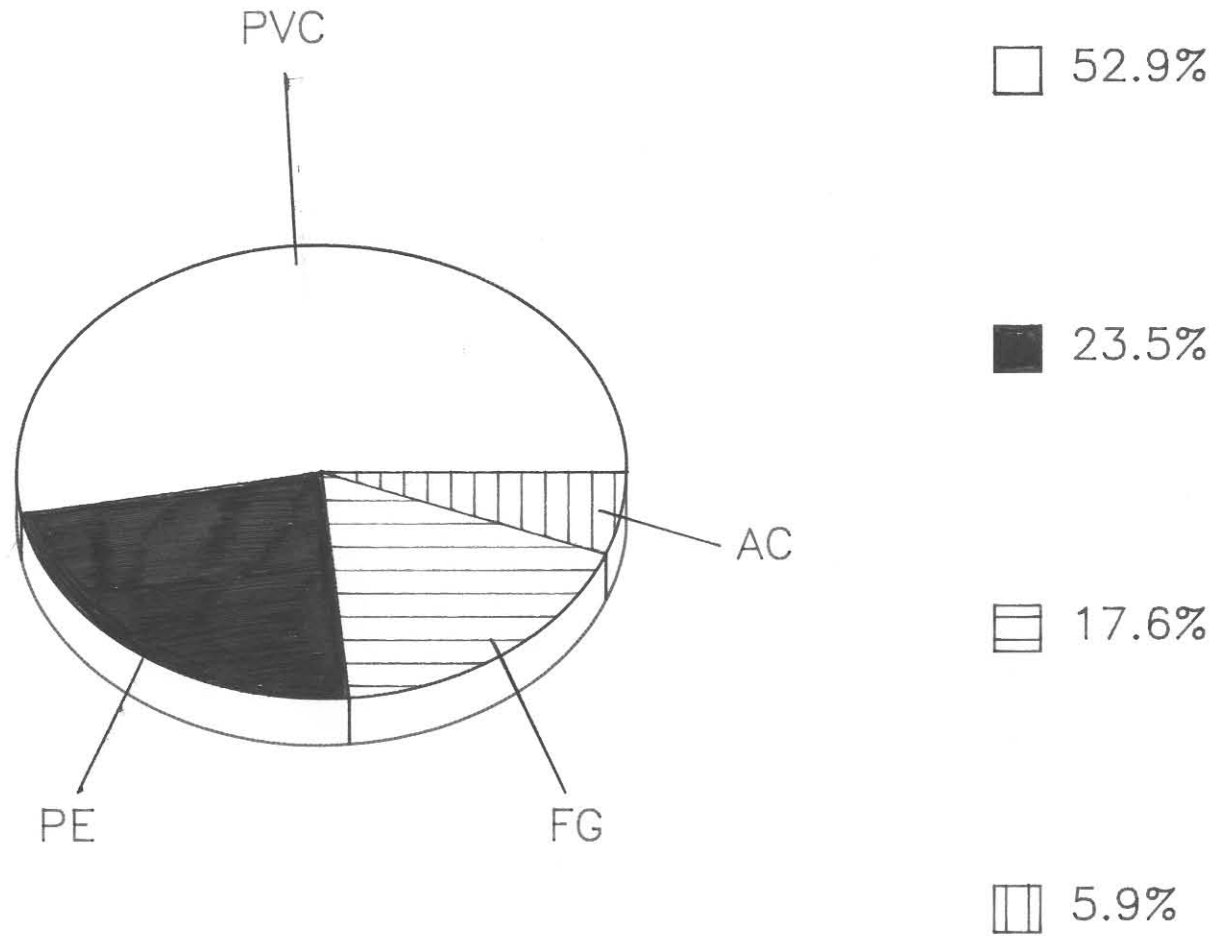

Comparison of Survey Results (Interest in Piping by Type)
to Existing Stock of Piping in Service

Figure 12

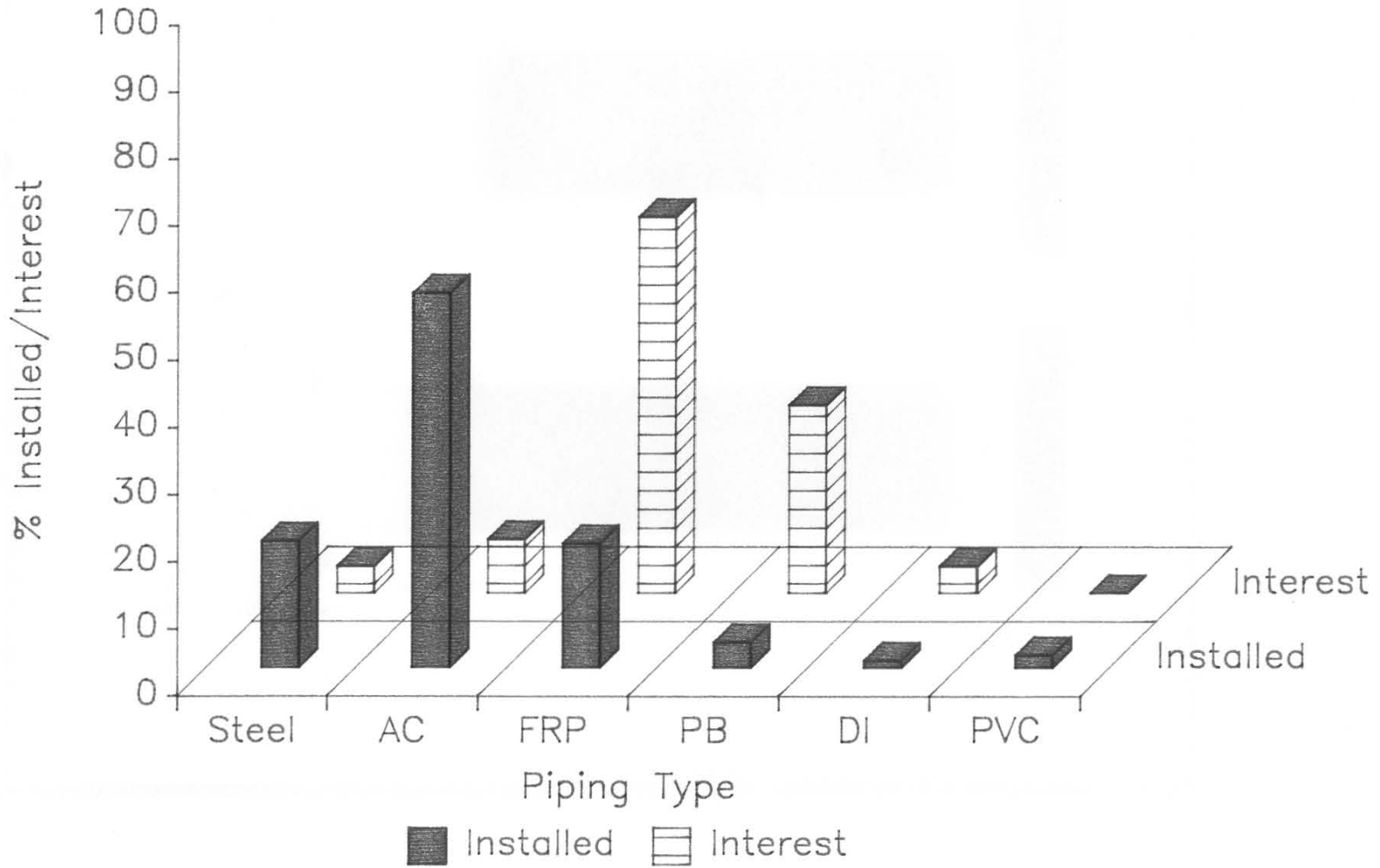

It is important to note that the survey failed to include some piping products which may be of interest for geothermal district heating applications. Two of the newer products in the group (see appendix) include slip joint (gasketed) fiberglass and slip joint steel. The design of this piping reduces both the skill and magnitude of labor required to assemble the piping system.

Performance of Existing Piping (Rafferty, 1989)

Mainline piping, in general, has been one of the more reliable areas of the system for most district heating operations. Isolated problems have occurred; however, no consistent failures with any particular piping material have been identified.

Asbestos cement piping has been quite successful in geothermal district heating applications. Occasional failures have occurred; however, most of these were related to poor installation techniques (bedding). In addition, leaks at piping connections related to poor lubrication or assembly techniques have occurred on some systems.

The single largest problem associated with AC system has been with fittings. All of the AC piping designs employ ductile iron fittings. These are generally left uninsulated. As a result, exterior corrosion has been a problem in some areas. This has been most pronounced in saddle tap fittings. Corrosion of this type has generally been address successfully through the use of stainless steel fasteners and fusion bonded epoxy coatings on ferrous components.

Steel piping has performed well in most geothermal applications. In only one instance has significant failure occurred. The OIt distribution system, originally installed in 1963, was a field

insulated direct buried design. After a period of approximately 10 years, the vapor barrier (asphalt impregnated fabric) deteriorated to the extent that ground water was able to come into contact with the exterior of the pipe. This resulted in numerous failures due to external corrosion. Although portions of this piping remain, the system has been largely rebuilt with epoxy adhesive joint, pre-insulated fiberglass piping installed in concrete tunnels.

The remaining installations, in which steel piping is used, all employ newer pre-insulated products. This material has provided trouble-free service in all instances.

Fiberglass piping used in most geothermal applications has been of the epoxy resin, adhesive joint variety. One system employed a mechanical joint (key-lock) product. It was the mechanical joint system which experienced the most difficulty.

Much of the Klamath Falls City system's distribution network was constructed of a key-lock type mechanical joint fiberglass product. After the first year of operation, a number of leaks began to appear in the system. These leaks occurred exclusively at the mechanical connections and no failures were noted in the piping itself. The nature of the failure was related to a component in the connection which was epoxied onto each length of pipe at the factory. The epoxy used to attach a grooved lock ring to the pipe was either improperly prepared or was not suitable for the

temperature of the application. This epoxy failed allowing the lock ring to slip (axially) on the pipe and result in leaks.

Initially, an attempt was made to repair these leaks; however. The frequency of occurrence quickly resulted in the necessity to shut the system down. All of the fiberglass pipe will be replaced.

The Klamath Falls system experience should not be considered an indictment of fiberglass material in general. Numerous applications of fiberglass piping have been successful in geothermal applications. Three major district heating systems employ substantial quantities of epoxy adhesive type fiberglass piping. No failures of piping have been reported in any of these systems.

Pre-insulated polybutylene (PVC jacket) piping was employed for main distribution lines in one of the systems reviewed. The entire distribution was constructed of this material with butt fusion joining used throughout. This system has been in operation for approximately 6 years and no problems with the piping have been reported. Some difficulties were experienced at installation. Due to the flexible nature of the material bending stress tended to be concentrated at locations where the jacketing and insulation were removed (at fittings). Special handling was required during installation to prevent kinking the pipe at these locations.

Until recently, ductile iron piping has not been used in geothermal systems, although fittings of this material have been extensively used in conjunction with asbestos cement pipe. The operators of the San Bernardino system have recently installed several thousand feet of ductile iron in their systems. This pipe is internally lined with coal tar epoxy (distribution temperatures on the order of 130°F). Ductile iron was chosen primarily on the basis of economics and ease of installation in comparison to the previously used asbestos cement (Fisher, 1989).

PVC and CPVC have seen only limited use in district systems. In the few installations where these materials were installed, solvent weld type joining practices were employed. Both systems in which the pipe was used have experienced multiple joint failures. In one situation, this was likely the result of insufficient allowance for expansion. In the second case, the cause of failure is less clear. If PVC or CPVC materials are to be used for district installations expansion allowances should be given careful consideration. In the case of PVC, gasketed pressure pipe may be an alternative.

Piping Cost

The cost of piping for a district heating project is influenced by a host of factors, including:

Material type

Size

Joining method

Purchase quantity

Vendor

Number of fittings

Routing

Existing utilities

Funding source

Temperature/pressure requirements

Direct buried or tunnel installation

As a result, it is difficult to provide meaningful price information in a general report such as this. However, cost is an important factor and frequently the most important factor in material selection. To address this issue, data were drawn from a number of sources to develop the relative costs appearing in Figures 13 and 14. These sources (References 1-5) included recent project cost data, vendor quotes, and values from various

construction cost estimating manuals. In the case of both figures, the relative costs are indexed to 6" asbestos cement pressure pipe which is currently the most common material found in U.S. geothermal district heating systems.

Fourteen different piping types are included in the cost data appearing in Figure 13. These include:

- AC - Asbestos cement pressure pipe, class 150
- DI - Cement lined ductile iron pipe, Tyton joint, class 50
- STL-S - Schedule 40 steel pipe with slip (gasketed) connections
- STL-W - Schedule 40 steel pipe with welded connections
- PVC-S - Schedule 40 PVC, solvent welded connections
- PVC-G - Class 160 PVC, gasketed connections
- CPVC - Schedule 40 CPVC, solvent welded connections
- PE - SDR 13.5 polyethylene, butt fusion connections
- PB - SDR 13.5 polybutylene, butt fusion connections
- FRP-M - Epoxy resin fiberglass, resin liner, keyed-mechanical joining
- FRP-EM - Epoxy resin fiberglass, resin liner, epoxy adhesive joining 150 psi/250°, military spec.
- FRP-E - Epoxy resin fiberglass, unlined, epoxy adhesive joining 150 psi/210°
- FRP-S - Epoxy resin fiberglass, resin liner, slip type gasketed joining
- FRP-T - Epoxy resin fiberglass, unlined, integral threaded connections

Relative Cost of Piping by Type

Figure 13

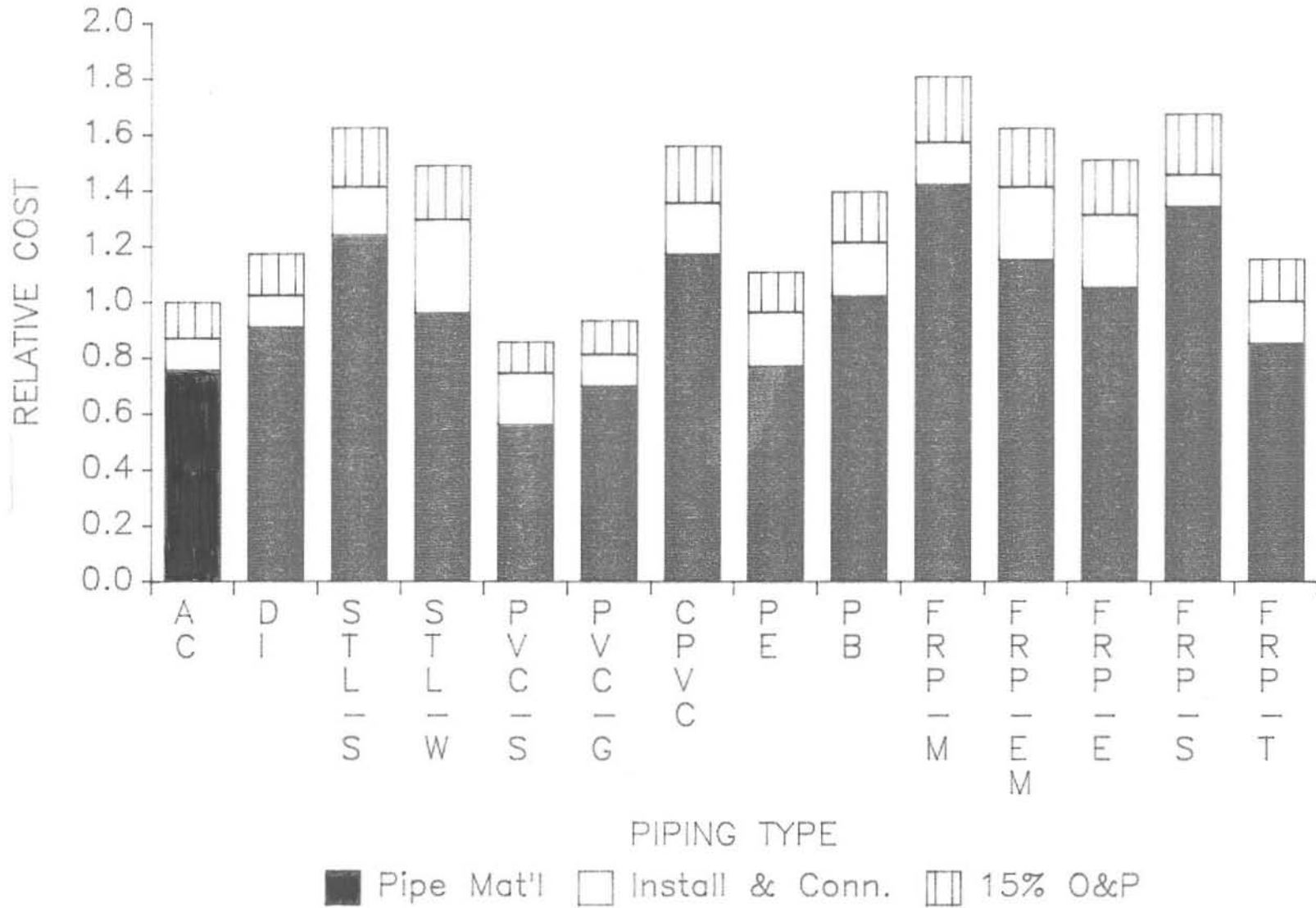

The cost data appearing in Figure 13 is divided into 3 sub parts: pipe material, installation and connection, and 15% overhead and profit.

The pipe material numbers included only values for 6 inch straight pipe. No costs have been included for fittings, valves, expansion loops or joints. The installation and connection values include costs associated with connecting the pipe for materials (lubricants, solvents, adhesives, joint installation kits [steel pipe], etc.), and equipment (fusion machine, welder, heat blankets, etc.). Finally, a 15% construction overhead and profit adjustment is added to each material. No costs have been included for trenching, backfill and thrust blocks since these are highly site specific.

Figure 14 presents cost data (again relative to asbestos cement) for 90° elbows typical of that employed for each of the piping types. As indicated, the costs associated with fittings for many nonmetallic piping products are significantly higher than for steel and ductile iron materials.

Relative Cost of 90° Elbow Fitting Cost by Type

Figure 14

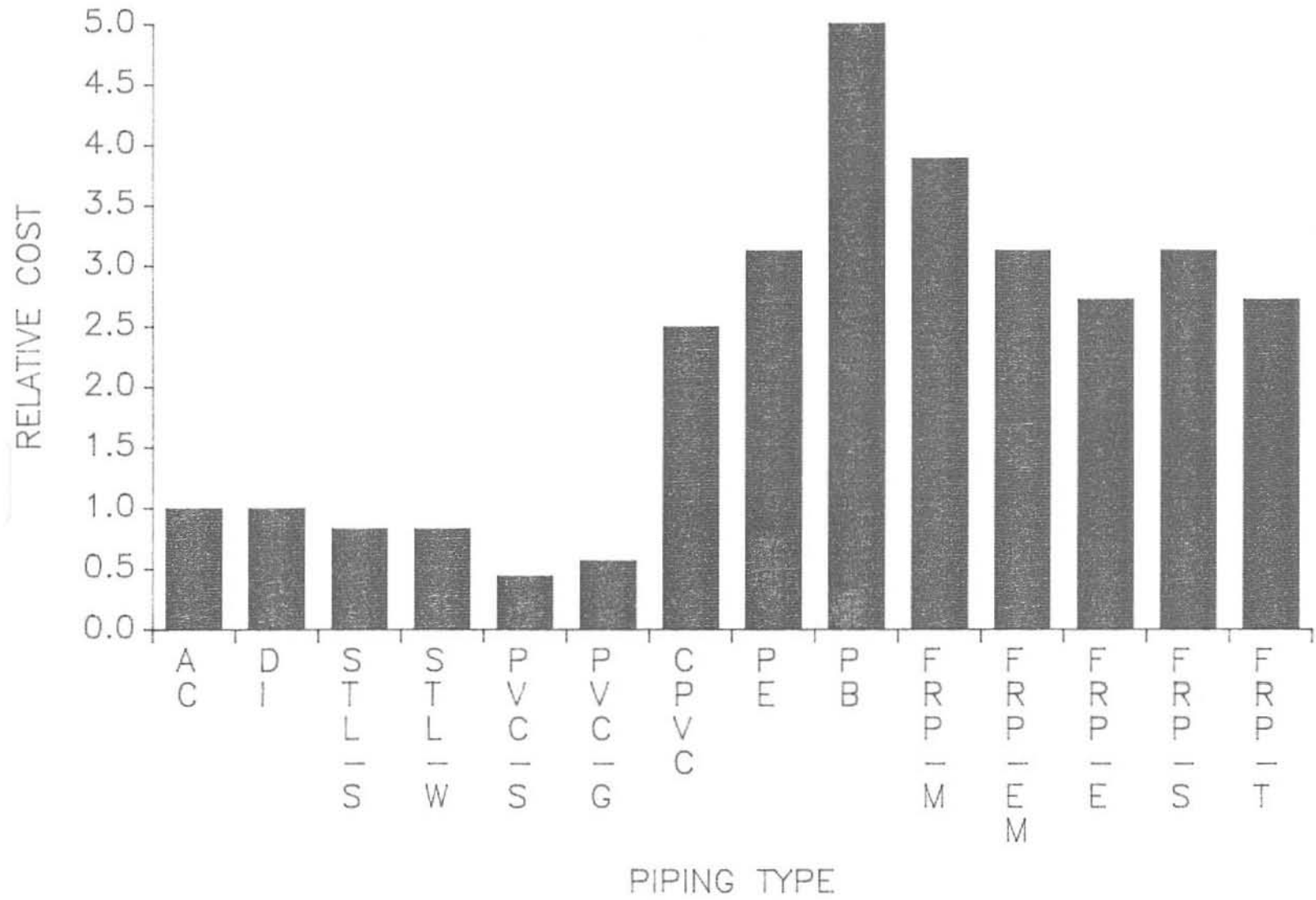

Uninsulated Piping

High initial capital costs are one reason development has lagged in the area of district heating. Much of this cost (40 to 60%) is associated with the installation of the distribution piping network. The use of uninsulated piping for a portion of the distribution offers the prospect of reducing the piping material costs by more than 50%.

Although the uninsulated piping would have much higher heat loss than insulated lines, this could be compensated for by increasing system flow rates. The additional pumping costs to maintain these rates would be offset by reduced system capital costs. Preliminary analysis indicates that it would be most beneficial to use uninsulated lines in sizes above about 6" in certain applications.

It is important before discussing the specifics of uninsulated piping to draw a clear distinction between heat loss (measured in Btu/hr lf) and temperature loss (measured in °f/lf). Heat loss from a buried pipeline is driven largely by the temperature difference between water in the pipe and the ambient air. The temperature loss which results from the heat loss is a function of the water flow in the line. As a result, for a line operating at a given temperature, the greater the flow rate the lower the temperature drop. In geothermal systems, the cost of energy is primarily related to the pumping; this results in the low energy cost relative

to conventional district systems and the ability to sustain higher energy losses (of the uninsulated piping) more economically.

Figure 15 illustrates the relationship of heat loss and temperature loss. The figure is based upon 6" pre-insulated (1.8" insulation, PVC jacket, FRP carrier pipe) and 6" on insulated pipe buried 4 feet below the ground and operating at 170°F inlet temperature. Temperature loss per 1,000 feet is plotted against flow rate. As discussed above, the graph indicates the substituted increase in temperature loss at low flow rates.

The prospect for the use of uninsulated piping is greatest for larger sizes (>6"). This is related to the fact that in larger sizes the ratio of the exposed surface area (pipe outside surface area) compared to the volume (flow capacity) is reduced. This relationship reduces the heat lost per gallon of water passed through the line.

If the use of uninsulated piping is to be economically attractive, a high load factor (total annual flow divided by peak flow) is required. In many district systems, initial customer flow requirements amount to only a small fraction of the distribution capability. Many years are required for the system to approach full capacity. Under these conditions, the system is operated at very low load factor initially and the economics of uninsulated piping would likely not prove to be favorable.

Buried Pipeline Temperature Loss Versus Flow Rate

Figure 15

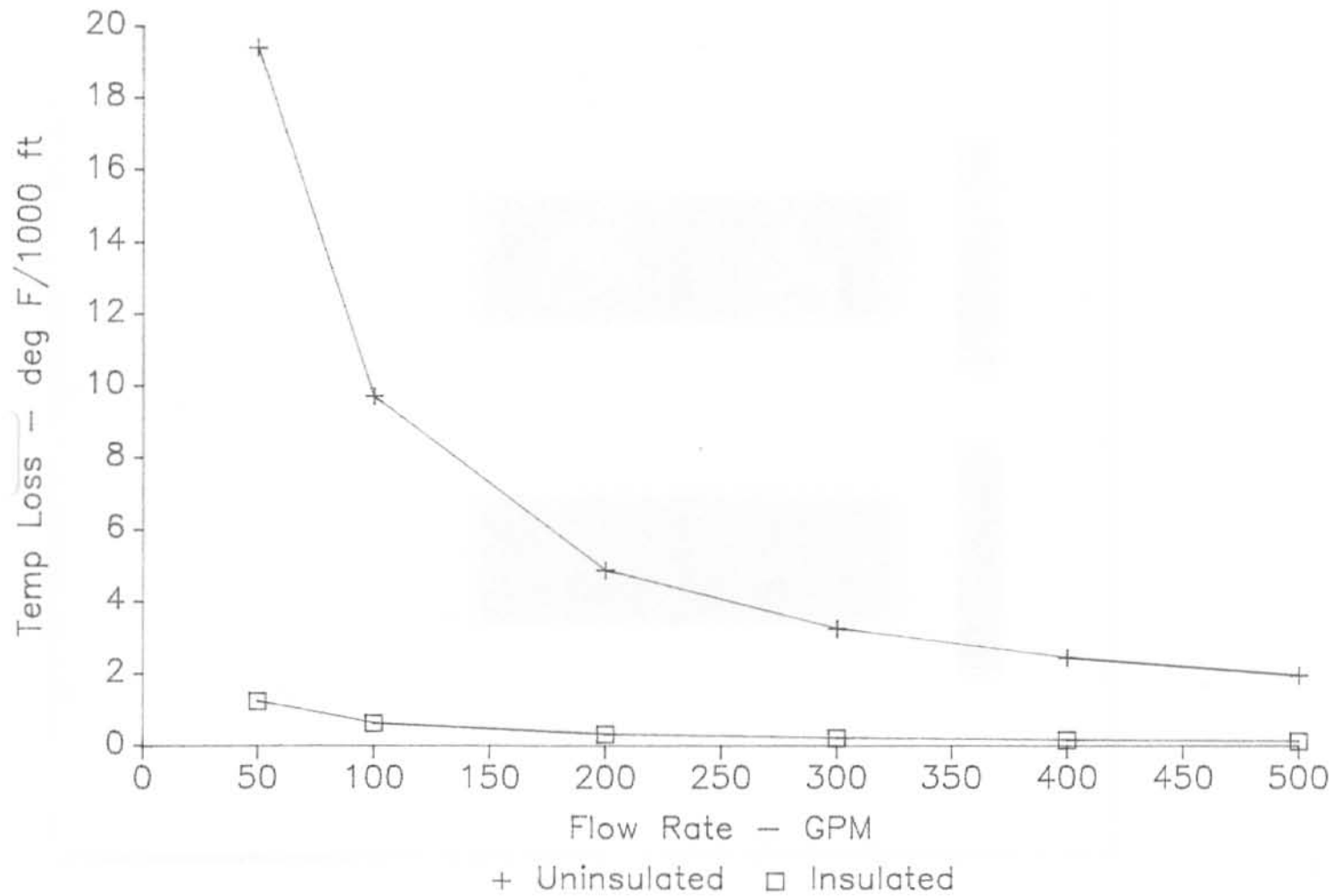

Systems designed for the existing group of buildings or those which serve process loads are more likely candidates for the use of uninsulated piping.

Table 1 presents the results of an example of uninsulated pipe used for a specific case. The table is based on the following:

- ❖ 6" fiberglass pipe line
- ❖ 170° water temperature
- ❖ 4 feet burial depth
- ❖ Soil conductivity = 10
- ❖ Design velocity 5 ft/sec (450 gpm)
- ❖ Minimum flow = 15% of design (68 gpm)
- ❖ Minimum flow occurs at temperatures above 60°F
- ❖ Between 0° (design temperature) and 60°F a linear reduction in flow occurs (from 450 to 68 gpm)
- ❖ Average well pump efficiency = .63
- ❖ Pumping level = 200'
- ❖ Well head pressure requirement = 40 psi
- ❖ Electricity costs \$0.07/kwh
- ❖ Allowable temperature drop = 2°F
- ❖ Line length = 1,500'

Column 1 contains the outside temperature values. Column 2 contains the annual number of hours at each outside temperature. Column 3 provides the system flow requirement at each outdoor temperature. The temperature drop across the line for each temperature appears in Column 4. The required flow to maintain a 2°F temperature drop appears in Column 5. Column 6 is the excess flow (above system

requirements) to maintain a 2°F temperature drop. Column 7 shows the required well pump kw to provide the excess flow. Column 8 indicates the total annual kwh consumption for temperature maintenance for each outside temperature.

In this particular case, the elimination of insulation on 1,500', 6" line would save approximately \$15,000 in capital costs. The first year cost of electricity to compensate for the lack of pipe insulation amounts to \$1,568.

Assuming the owner was financing the project at 9% for 20 years and that electricity inflates at 7% per year, the simple payback on the insulation for the pipe is in excess of 15 years.

Table 1

Base Loss 140.6 Btu/hr lf

1	2	3	4	5	6	7	8
Outside air temp. °F	Hrs/yr	Flow gpm	Δt °F	Flow for 2° Δt	Excess flow gpm	Pump kw	Annual kwh
2	17	450	0.94	--	0	0	0
7	39	414	0.98	--	0	0	0
12	82	374	1.05	--	0	0	0
17	150	338	1.12	--	0	0	0
22	352	302	1.22	--	0	0	0
27	675	261	1.36	--	0	0	0
32	1132	225	1.52	--	0	0	0
37	1044	189	1.75	--	0	0	0
42	931	149	2.13	159	10	0.873	813
47	826	113	2.70	153	39	3.460	2706
52	783	77	3.80	146	69	6.050	4743
57	658	68	4.12	140	72	6.300	4145
62	551	68	3.94	134	66	5.760	3173
67	468	68	3.76	128	60	5.220	2442
72	373	68	3.58	122	54	4.710	1758
77	313	68	3.40	115	47	4.130	1294
82	235	68	3.21	109	41	3.600	845
87	124	68	3.02	103	35	3.050	379
92	39	68	2.85	97	29	2.510	98
	8792						22396

22396 kwh @ 0.07/kwh = \$1,568/yr

1500 lf * \$10/lf savings = \$15,000

Items Important to the Consideration of Uninsulated Piping:

1. Cost of Pumping. This is influenced primarily by the overall pumping system efficiency, cost of electricity, well pumping level, well head pressure requirements, and pump capacity control (throttling valve, variable speed drive, etc.). As the unit cost of pumping increases, the attractiveness of uninsulated pipe decreases.
2. System Load Factor. The higher the load factor, the more practical uninsulated piping becomes. Higher system load factor reduces the quantity of excess water which must be pumped to maintain supply temperature.
3. Allowable Temperature Drop. The more temperature which can be sacrificed, the greater the possibility to use uninsulated piping. Allowable temperature drop must be carefully balanced against resource temperature and customer needs. In the example, had a 3° rather than 2° drop been acceptable, annual pumping costs for temperature maintenance would have been reduce from \$1,568 to \$369 per year for the line. A four degree drop would have eliminated excess pumping completely.

4. Proximity of other utilities. Close proximity to some telephone, electric or water utility lines may preclude the consideration of uninsulated lines due to temperature effects.

5. Disposal Method. It is apparent from the example that most excess flow requirements occur during the summer months. If surface disposal is employed, low surface water flows (rivers) may influence the maximum rate of geothermal disposal based on chemical or thermal pollution.

6. Customer Contract. Allowance for lower temperature supply water during the warmer portion of the year could reduce the requirement for excess pumping for temperature maintenance.

7. Piping Type. The use of uninsulated piping would be less attractive with respect to steel and possibly ductile iron. These materials would likely require exterior protection if uninsulated. This would reduce the savings achieved through the use of inunsulated pipe.

8. Local Soil Conditions. Soils of high thermal conductivity or wet areas tend to increase heat loss from piping. These areas would reduce the potential for uninsulated piping.

9. System Water Temperature. Lower temperature systems may be better candidates for uninsulated pipe use.

10. Line Size. As discussed earlier, larger lines (>6") are more likely to yield positive results with respect to the use of uninsulated pipe.

Considerations in the Application of Various Piping Materials

Asbestos Cement

- Regulatory restrictions
- Epoxy lining
- Temperature rating of gaskets
- External protection of cast iron fittings
- Interior lining of cast iron fittings
 - Coal tar epoxy <130°
 - Cement lining with seal coat <150°
 - Bare cement lining (w/o seal coat) <212°
 - Compatibility of cement lining w/geo fluid
 - Delivery time for unlined and bare cement lined fittings
- Temperature rating and material used in repair fittings
 - Gaskets
 - Carbon steel fasteners (external corrosion potential)

Ductile Iron (Tyton Joint)

- Internal coating (see asbestos cement fittings)
- Gasket temperature compatibility
- External protection at connections

Fiberglass

- Connection method
 - Epoxy adhesive

- o Threaded
 - Integral
 - Non-integral
- o Mechanical
- o Slip coupling (gasketed)
- Internal lining
- Temperature suitability
- Potential for formation of water vapor (flashing)
- Fitting costs
- Special equipment and skills (magnitude depends on connection method)
- Factory representative at installation
- Availability
- Cost of joint kits (epoxy adhesive joints)

Steel

- Potential for corrosion due to introduction of O₂ in system (from tanks, etc.)
- Expansion compensation
- Connection method
 - o Welded
 - o Mechanical
 - o Slip joint (gasketed)
- Fluid compatibility (pH, dissolved CO₂)
- Quality of jacketing/joint connection kits (external corrosion)

Polybutylene

- Temperature/pressure requirements (wall thickness - SDR)
- Special equipment/skills for fusion binding
- Factory representative at installation
- Fitting costs
- Rigging techniques (lack of rigidity)
- Availability
- Joining method for valves, etc.

Polyethelene

- Same as Polybutylene except for much lower temperature/pressure ratings

CPVC

- Material and fittings costs
- Connection method
 - Solvent weld
 - Gasketed (?)
 - Temperature rating of gaskets
- Solvent weld joining requires careful allowance for expansion

PVC

- Same as CPVC except for lower temperature and pressure ratings

Pre-Insulated Piping in General

- Necessity of pipe insulation
- Jacket material
 - PVC
 - Fiberglass
 - Polyethylene
 - Other
- Jacket thickness requirement
- End seals
 - Rubber inserts
 - Mastic coating
- Insulation thickness requirement
- Cost of joint insulation kits

References

1. Andrews, J., Western Regional Manager, Thermal Pipe Systems, Inc., Corbett, OR, Personal Communications, 1989.

2. Fisher, K. and Rafferty, K., "Do It Yourself Piping - The San Bernardino Way," Geo-Heat Center Quarterly Bulletin, Vol. 11, No. 2, 1988, Oregon Institute of Technology, Klamath Falls, OR.

3. Dellinger, M., Geothermal Coordinator, Lake County, CA, Personal Communications, 1989.

4. Means, R. S., Means Mechanical Cost Data - 1988, R. S. Means, Inc., Kingston, MA, 1987.

5. Rafferty, K., A Materials and Equipment Review of Selected U.S. Geothermal District Heating Systems, Oregon Institute of Technology, Geo-Heat Center, Klamath Falls, OR, 1989.

APPENDIX



Thermal Pipe Systems, Inc.

HEAT-TITE

**FOR UNDERGROUND DISTRIBUTION OF LOW TEMPERATURE
HOT WATER AND CHILLED WATER SERVICE**

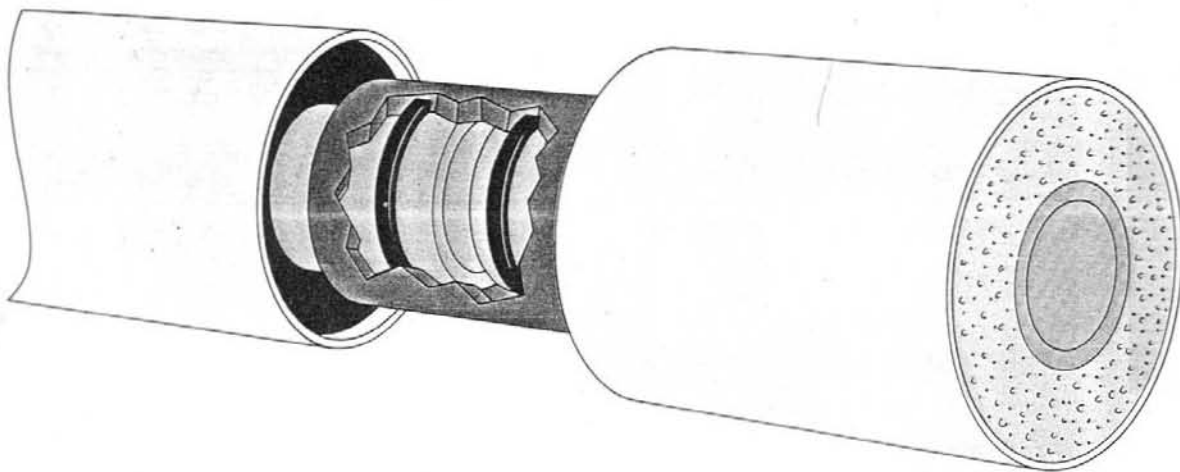

Pre-insulated Heat-Tite Pipe is an easy to install, energy efficient piping system for low temperature hot water and chilled water service. This system may be used for water only in temperatures up to 250°F and pressures to 150 psi.

The standard carrier pipe is schedule 40 ASTM A53 or A106 steel pipe with the sealing surface protected to prevent corrosion. The system is produced with a FRP grooved coupling containing a high temperature resistant rubber "V" ring. Insulation is a thermally efficient polyurethane foam with a "K" factor of 0.14 @ 70°F. The casing is heavy wall P.V.C. Heat resistant

end seals keep the insulation dry. Pre-insulated fittings are available.

Joining Heat-Tite Pipe is simple. Lubricate the spigot end and push it home. This rubber ring joint compensates for thermal expansion and contraction and earth movement without additional stress on the pipe. There is no need for loops or other expansion devices.

The exclusive T.P.S. Casing-Tite Coupling provides an easy and efficient means of insulating joints where necessary.

PRE-INSULATED HEAT-TITE® PIPE

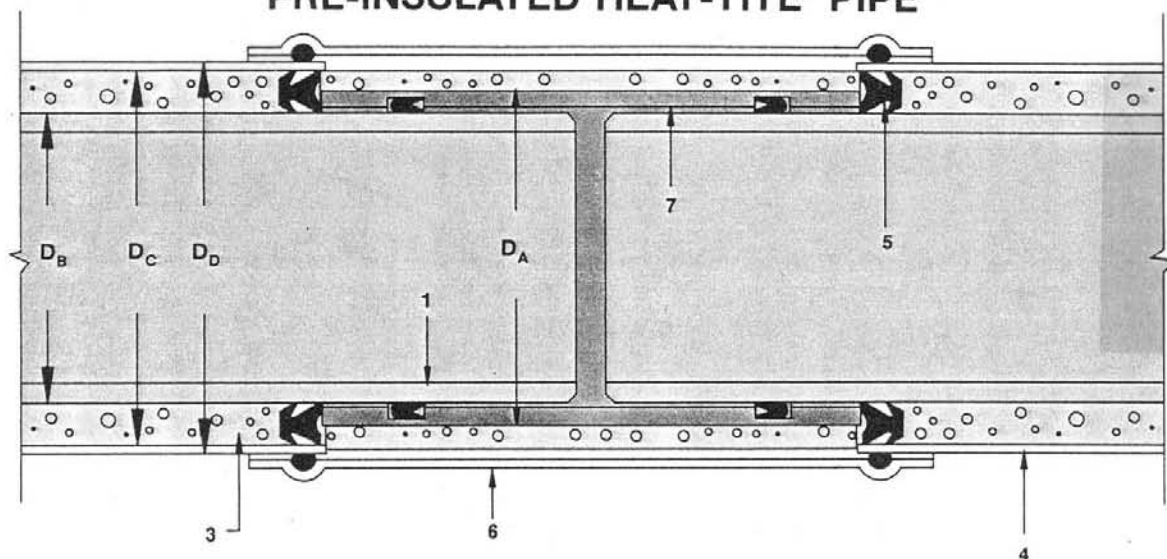

- | | |
|--|--|
| <p>1) CARRIER: Black Steel as Specified
 2) CARRIER SEALING RING: H.T. Rubber
 3) INSULATION: Polyurethane Foam
 4) CASING: Polyvinyl Chloride (PVC)</p> | <p>5) END SEAL: H.T. Rubber
 6) CASING-TITE COUPLING: (PVC)
 7) COUPLING: Grooved FRP
 8) CASING SEALING RING: H.T. Rubber</p> |
|--|--|

PIPE SIZE	CASING SIZE	D _B	D _C	D _D	D _A	T _C	T _I	WEIGHT LBS./SEC.
2	4	2.38	4.22	4.50	3.52	.14	.92	99
3	6	3.50	5.90	6.27	4.82	.19	1.20	188
4	8	4.50	7.92	8.40	5.82	.24	1.71	280
6	10	6.63	9.90	10.50	7.94	.30	1.64	477
8	12	8.63	11.76	12.50	10.86	.37	1.54	707
10	15	10.75	14.76	15.30	12.03	.27	2.00	104
12	15	12.75	14.76	15.30	14.05	.27	1.00	1351

SHORT FORM SPECIFICATION

1.1 All underground insulated pipe 2"-12" shall be Thermal Pipe Systems Heat-Tite Pressure Pipe with Ring-Tite joints.

1.2 Core pipe shall be suitable for use at maximum hydrostatic working pressures of 150 psi at 250° F. All pipe shall be steel as specified by the design engineer.

1.3 Joints shall automatically provide for expansion and contraction through the sealing rings placed in the grooves of the FRP joining

coupling. Pipe must be assembled with the lubricant supplied by TPS.

1.4 Casing pipe shall be Polyvinyl Chloride (PVC) meeting the minimum classification requirements of ASTM D 1784. The thickness shall be in accordance with TPS published data.

1.5 Pipe joints shall be insulated using polyurethane half shells. Joints shall be closed using a two ring Casing-Tite coupling supplied by TPS.

1.6 The insulation shall be polyurethane closed cell foam completely encapsulated on each end by a compressed rubber end seal.

1.7 Fittings may be uninsulated, using welded steel or cast iron class 150 fittings with a groove and rubber ring. Fittings may also be factory preinsulated using the same carrier, insulation, casing and rubber end seals as the straight lengths of pipe.

WARRANTY

We warrant that our products are manufactured with the applicable material specifications and are free from defects in workmanship and material using our specifications as a standard. Every claim under this warranty shall be deemed waived unless in writing and received by Thermal Pipe Systems, Inc. within thirty (30) days of the date the defect was discovered or should have been discovered and within one (1) year of the date of the shipment of the product. THERMAL PIPE SYSTEMS, INC., MAKES NO OTHER REPRESENTATION OR WARRANTY OF ANY KIND, EXPRESS OR IMPLIED, IN FACT OR IN LAW, INCLUDING WITHOUT LIMITATION THE WARRANTY OF MERCHANTABILITY OR THE WARRANTY OF FITNESS FOR A PARTICULAR PURPOSE, OTHER THAN THE LIMITED WARRANTY SET FORTH ABOVE.

LIMITATION OF LIABILITY

It is expressly understood and agreed that the limit of Thermal Pipe Systems, Inc., liability shall be the resupply of a like quantity of nondefective Product and that Thermal Pipe Systems, Inc., shall have no such liability except where the damage or claim results solely from breach of Thermal Pipe Systems, Inc. warranty. IT IS ALSO AGREED THAT THERMAL PIPE SYSTEMS, INC., SHALL NOT BE LIABLE FOR ANY INCIDENTAL, CONSEQUENTIAL, OR OTHER DAMAGES FOR ANY ALLEGED NEGLIGENCE, BREACH OF WARRANTY, STRICT LIABILITY, OR ANY OTHER THEORY, OTHER THAN THE LIMITED LIABILITY SET FORTH.



Thermal Pipe Systems, Inc.

FRP VEE TITE® PIPE

FOR UNDERGROUND DISTRIBUTION OF CONDENSATE AND
LOW TEMPERATURE HOT WATER SERVICE

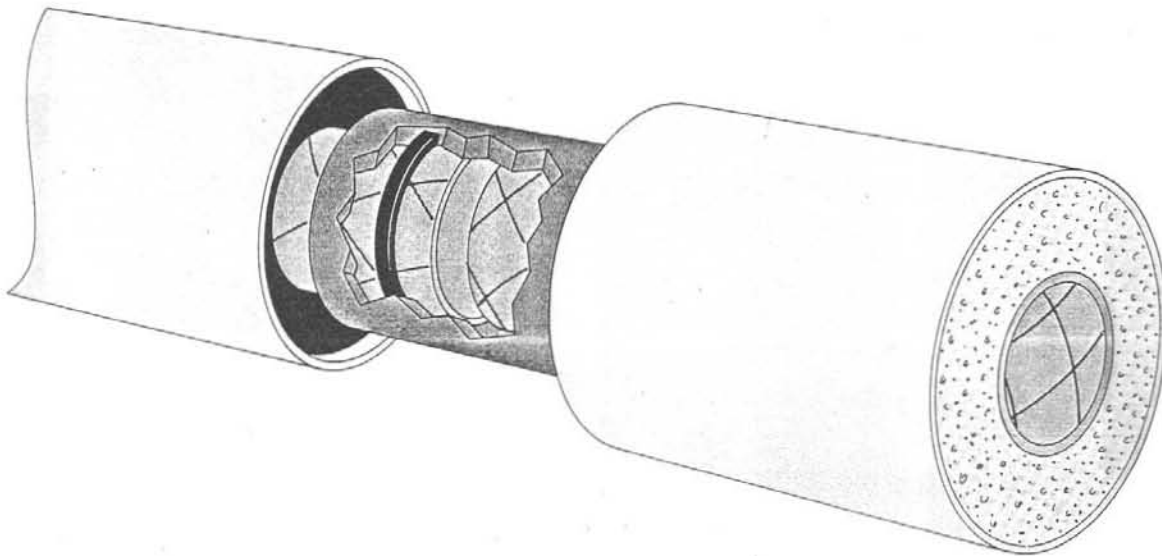

Pre-insulated FRP Vee-Tite Pipe is a lightweight, easy to install, energy efficient piping system for low temperature hot water condensate return service. The system may be used for water only in temperatures to 250°F and pressures to 150 psi.

The carrier is filament wound epoxy resin pipe with a resin-rich liner. It meets Mil. Spec. Mil-P-28584A. The system is produced with a grooved FRP coupling containing a high temperature resistant rubber ring. Insulation is thermally efficient polyurethane foam with a "K" factor of 0.14 at 70°F. Casing is heavy wall P.V.C.. Heat resistant end seals keep the insulation dry. Various fittings are available and it is easily adapted to existing steel systems.

Joining FRP Vee-Tite Pipe is simple. Lubricate the spigot end with the lubricant provided and push it home. This rubber ring joint compensates for thermal expansion and contraction and earth movement without additional stress on the pipe. The piping system is non corrodible and maintains its high flow characteristics. It is an excellent choice for underground condensate return lines, district heating systems, dual temperature lines and geothermal heating systems. This piping system is approved for use by Federal Agencies under FCGS 15705.

The exclusive T.P.S. Casing-Tite Coupling provides an easy and efficient means of insulating joints where necessary.

PRE-INSULATED FRP VEE-TITE® PIPE

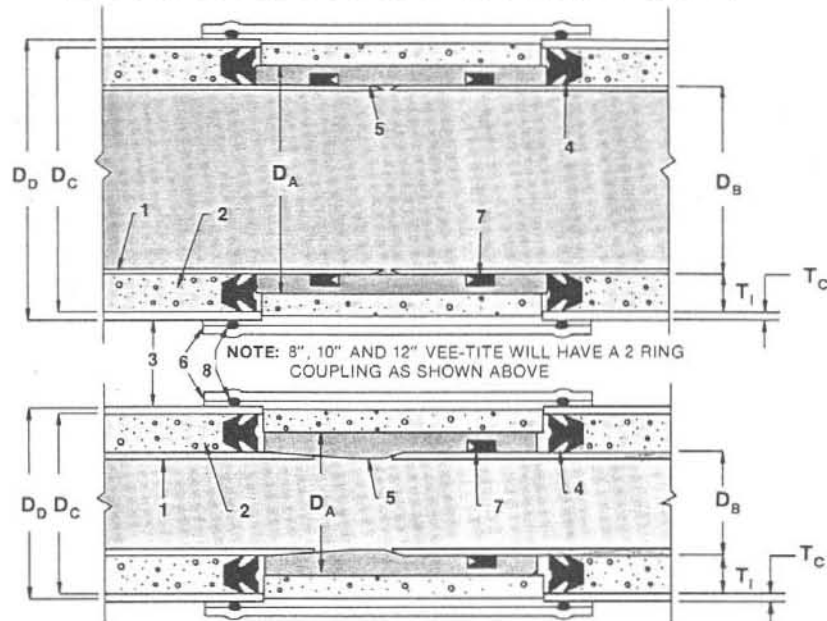

NOTE: 2"-6" VEE-TITE WILL HAVE A BONDED 1 RING COUPLING AS SHOWN ABOVE

- | | | |
|----------------------------------|------------------------------|---------------------------------------|
| 1) CARRIER: FRP | 4) END SEAL: H.T. Rubber | 7) CARRIER SEALING RINGS: H.T. Rubber |
| 2) INSULATION: Polyurethane Foam | 5) COUPLING: Grooved FRP | 8) CASING SEALING RINGS: H.T. Rubber |
| 3) CASING: Polyvinyl Chloride | 6) CASING-TITE COUPLING: PVC | |

PIPE SIZE	CASING SIZE	D _B	D _C	D _D	D _A	T _C	T _I	WEIGHT LBS./SEC.
2	4	2.38	4.22	4.50	3.52	.14	.92	35
3	6	3.50	5.90	6.27	4.82	.19	1.20	57
4	8	4.50	7.92	8.40	5.82	.24	1.71	94
6	10	6.63	9.90	10.50	7.94	.30	1.64	152
8	12	8.68	11.76	12.50	10.86	.37	1.54	214
10	15	10.74	14.76	15.30	12.03	.27	2.01	329
12	15	12.72	14.76	15.30	14.05	.27	1.02	495

SHORT FORM SPECIFICATION

1.1 All underground insulated pipe 2"-12" shall be Thermal Pipe Systems Vee-Tite Pressure Pipe with Ring-Tite joints.

1.2 Core pipe shall be suitable for use at maximum hydrostatic working pressures of 150 psi at 250° F. All pipe shall be Fiberglass Reinforced Plastic (FRP), shall have a resin rich liner and shall comply with ASTM D 2310, D 2996 meeting Mil Spec 28584A.

1.3 Each joint shall automatically provide for expansion and contraction through the heat

resistant sealing ring (Ethylene Propylene Diene Monomer) placed in the groove of the FRP joining coupling. Pipe must be assembled with the lubricant supplied by Thermal Pipe Systems.

1.4 Casing pipe shall be Polyvinyl Chloride (PVC) meeting the minimum classification requirements of ASTM D 1784. The thickness shall be in accordance with TPS published data.

1.5 The insulation shall be polyurethane closed cell foam completely encapsulated on

each end by a compressed heat resistant rubber end seal. Pipe joints shall be insulated using polyurethane foam half shells and protected with a rubber ring Casing-Tite coupling of the same material and thickness as the casing pipe.

1.6 Fittings shall be uninsulated FRP designed to be used with the carrier pipe. Fittings shall have a bell with a taper to match a properly tapered spigot end of the pipe. The fittings shall be joined with an adhesive meeting the operational requirements of the system.

WARRANTY

We warrant that our products are manufactured with the applicable material specifications and are free from defects in workmanship and material using our specifications as a standard. Every claim under this warranty shall be deemed waived unless in writing and received by Thermal Pipe Systems, Inc. within thirty (30) days of the date the defect was discovered or should have been discovered and within one (1) year of the date of the shipment of the product. THERMAL PIPE SYSTEMS, INC. MAKES NO OTHER REPRESENTATION OR WARRANTY OF ANY KIND, EXPRESS OR IMPLIED, IN FACT OR IN LAW, INCLUDING WITHOUT LIMITATION THE WARRANTY OF MERCHANTABILITY OR THE WARRANTY OF FITNESS FOR A PARTICULAR PURPOSE, OTHER THAN THE LIMITED WARRANTY SET FORTH ABOVE.

LIMITATION OF LIABILITY

It is expressly understood and agreed that the limit of Thermal Pipe Systems, Inc. liability shall be the resupply of a like quantity of nondefective Product and that Thermal Pipe Systems, Inc. shall have no such liability except where the damage or claim results solely from breach of Thermal Pipe Systems, Inc. warranty. IT IS ALSO AGREED THAT THERMAL PIPE SYSTEMS, INC. SHALL NOT BE LIABLE FOR ANY INCIDENTAL, CONSEQUENTIAL, OR OTHER DAMAGES FOR ANY ALLEGED NEGLIGENCE, BREACH OF WARRANTY, STRICT LIABILITY, OR ANY OTHER THEORY, OTHER THAN THE LIMITED LIABILITY SET FORTH.



Thermal Pipe Systems, Inc.

P.O. BOX 443 PRIMOS, PA.
215-626-9655