

GEOTHERMAL HEATING OF KLAMATH FALLS SCHOOLS

John W. Lund, National Renewable Energy Laboratory, Golden, CO

Thomas E. Lund, Klamath Union High School, Klamath Falls, OR

ABSTRACT

Seven of Klamath Falls, Oregon public schools and college are heated with geothermal energy. All of the schools have individual wells, extracting the heat with either downhole heat exchangers, or pumping the water directly into the building heating system and then disposing of the water into injection wells. A student can attend all his schools, from grade school through to college, that are heated with geothermal energy. A description of the energy use and heating system for Roosevelt Grade School, Ponderosa Middle School, and Klamath Union High School are described - all of which the author (Thomas) has attended. Roosevelt Grade School has two wells in its playground/parking lot, each 150 m deep with temperatures around 90°C, using downhole heat exchangers to extract the heat. Ponderosa Middle School also uses downhole heat exchangers to extract the heat from a 170-m deep geothermal well at 93°C. This well is located near the original “Devil’s Tea Kettle”, a spring that was used by transients before being covered by highway construction. Klamath Union High School, due to its high heat demand, pumps the water directly from a geothermal well 78 m deep at 89°C, and then extracts the heat inside in the mechanical room. The spent water is then injection into a second well 76 m away. The high school also used to heat a swimming pool, site of an old natatorium that was used in the 1920s and 1930s. The wells are located on what was called “Big Springs”, the high school football field. These natural springs were used by the Native Americans and early European settlers for cooking food, bathing, and warming benches for ice skating. The total peak energy use of these three schools is 6.8 GJ/hr (2.0 MWth) and the annual energy use is 14.9 TJ/yr (4.1 GWh/yr), saving US \$206,000 annually in heating cost.

INTRODUCTION

Native American used the hot springs in the area for about 10,000 years, several of which were located within the present Klamath Falls City limits. These springs were used to cook game and for healing various ailments. The most famous of these springs were “Big Springs” located in the present Klamath Union High School athletic field, and “Devils Tea Kettle” located near the present Ponderosa Middle School athletic field. “Big Springs” was used by the European settlers during the early 1900s for cooking and scalding meat, cooking vegetables, bathing and just to keep warm (Lund, 1978). Picnic parties held at the hot springs were a favorite outing for the local residents. The area was flooded in the winter and used for ice skating. Benches were placed around the skating area and warmed underneath with hot water piped from the springs. In summer, these pools were used for swimming (Fig. 1 and 2). A bath house was constructed adjacent to the field in 1928, known locally as Butler’s

Natorium. Here both swimming and bathing were available, where 38 m³ of geothermal water were used daily during the summer months, as the water in the swimming pool was changed daily. Natural steam baths and mineral water tub baths were also available. The building was later replaced with the current structure for the high school field house and swimming pool. Water was also piped from the spring area to heat the White Pelican Hotel in 1911. Unfortunately, the hotel burned in 1926 and was replaced with the Balsiger Motor Company building, which still stands today, however, geothermal water is not longer supplied to this building.



KLAMATH COUNTY MUSEUM

Figure 1. “Big Springs” in the early 1900s.



KLAMATH COUNTY MUSEUM

Figure 2. “Big Springs” in the early 1900s.

“Devil’s Tea Kettle”, another hot springs area, was located near the present Ponderosa Middle School athletic field and the Klamath Falls City School District bus barn (Lund, et al, 1974). These springs are reported to have been used by transients to warm themselves and wash their clothes. Some, sleeping on boards above the springs, are reported to have rolled off in the night and scalded themselves. These springs,

the location of which the author (John) has attempted to find without success, appear to have been covered over by the construction of the Kit Carson Expressway in town. Adjacent excavations for the Bureau of Reclamation canal in 1906, opened hot springs in the banks of the canal that may have been related to the original “Devil’s Tea Kettle.”

In the 1890s local shearherders dug holes in the ground to obtain hot water in areas adjacent to the artesian springs. Around the turn of the century homes were heated by direct use of the artesian water, and both hot and cold water (after cooling in tanks overnight) were used for drinking and bathing. In 1925, residents started drilling wells using cable drilling methods in the area to the east of “Big Springs” in the Pacific Terrace area on the flanks of the large normal fault block that runs along the east side of the city. During the period from 1920 to 1932, plunger pumps were used on the dug and drilled wells due to the lack of knowledge concerning principles of “thermo siphoning” or the natural convection movement of hot water in a downhole heat exchanger. The first down-hole heat exchangers, designed and installed by Charlie Leib, an Austrian immigrant, was place in 1931 utilizing the thermo siphoning principal (Lund, 1974; Fornes, 1981; Culver and Lund, 1999) (Fig.3).

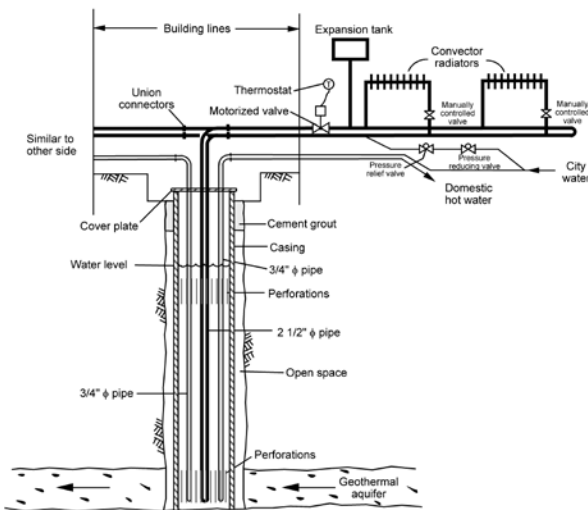

Figure 3. Examples of downhole heat exchangers.

Today most of the buildings in the eastern portion of the City of Klamath Falls are heated by hot water, including the three schools described in this paper: Roosevelt Elementary School, Ponderosa Middle School, and Klamath Union High School, all attended by the author (Thomas), along with the Oregon Institute of Technology (where the author - John - works) and a City district heating system (Brown, 2007; Lund and Boyd, 2009). Approximately 600 wells are used in the city for space heating, domestic hot water heating, heating of swimming pools, and for sidewalk snow melting (Boyd, 2003). The principal heat extraction system is the closed loop downhole heating exchanger utilizing city water in the heat exchanger. Some users, not using the downhole heat exchanger system or requiring more energy, pump the water directly from the well and run it through a plate heat exchanger transferring the heat energy to city water, and then dumping the spent geothermal water in to the storm sewer. Others pump

and dump directly into the storm sewer to improve the performance of their downhole heat exchanger (Culver and Lund, 1999). An injection well is required by the City for these systems, which include some residences and the Oregon Institute of Technology, Sky Lakes Medical Center, and the City district heating systems.

The present wells in the city vary from 30 to 600 m in-depth and produce fluids from 40 to 105°C, usually in a sub-artesian mode. Typical water chemistry for geothermal wells in the area tend to be high in sodium (201 mg/L) and sulfate (410 mg/L) and low in potassium (5 mg/L), calcium(22 mg/L) and chloride (49 mg/L), with silica at 91 mg/L. Total dissolved solids are 1000 mg/L and pH around 8.0 (slightly basic) (Lund, et al., 1976).

ROOSEVELT ELEMENTARY SCHOOL

Roosevelt Elementary School (named after President Theodore Roosevelt) (K through 6th grade) was built in 1928. It is a two-storied brick building with about 6,240 m² of floor space. Originally the building was heated by two large oil-fired boilers located in the basement. These boilers are still in the building, but unused. In 1960 two geothermal wells were drilled in the playground/parking lot on the east side of the building, as the school is located in one of the hottest geothermal zones in the city, with subsurface temperatures around 95°C. They were drilled to 152 m and completed with a 30.5-cm diameter casing perforated at three places below about 100 m. The temperature recorded at the time of drilling was 94°C. Measurements made in 1974 recorded 76°C at the top of the water column and 92.5°C at 107 m depth. Water level was at 24 m below the surface. Two black iron 6.4-cm diameter, closed loop downhole heat exchangers to around 100 m are used to extract heat from each well (Fig. 4). Originally, waste oil was poured down the well to coat the downhole heat exchangers at the air-water interface. This was to prevent pitting and corrosion of the pipes, which typically happens in most of the wells in Klamath Falls.



Figure 4. Roosevelt geothermal well.

Today, the water enters the building at 79°C and returns at varying temperature depending upon the outside temperature and building heating load. The water is circulated with a pump on the return line to the wells. City water is used in the downhole heat exchanger with the water then transferring heat directly to classrooms. Each classroom has baseboard radiators under the windows and supplemental forced air

through a vent in the interior wall. The heat flow is controlled manually in each classroom as the thermostats no longer work. There are three separate classroom loops, sidewalk snow melting loops for two street entrances (50 m²), and two large fan coil heat exchangers providing heated air to the auditorium and as supplemental heat for the classrooms (Figure 6). The domestic hot water in the cafeteria is boosted with natural gas. No cooling is provided to classrooms.



Figure 5. Roosevelt geothermal well with two 6.4-cm diameter downhole heat exchangers. The pipes in the upper part of the photo are connected to the second well.



Figure 6. One of the two large force air units supplying heat air to the auditorium and supplemental heat to the classrooms.

We estimate the peak use is 1.2 GJ/hr (0.35 MWth) and annual load of 2.7 TJ. This would amount to an annual savings of approximately \$37,000 as compared to natural gas or fuel oil.

PONDEROSA MIDDLE SCHOOL

Ponderosa Middle School (7th and 8th grades) was built in 1969, and has had several changes over the years. The most recent was the removal of a wing that was damaged by ground heaving and cracking, possibly caused by the shallow geothermal system. The school athletic field is also located adjacent to the estimated site of “Devil’s Tea Kettle” hot springs and right next to one of the major fault systems in the area supplying most of the geothermal water to the wells in the city. Today, there are 7,844 m² of floor space over a single story. Two geothermal wells were drilled, one in 1956 to 140 m and the other in 1969 to 171 m. The temperatures varied from 82 to 99°C (98°C is

boiling at our elevation of 1,370 m). The shallower well was originally used as a backup well and for sidewalk snow melting, but due to the failure of the snow melting pipes, is no longer used. The deeper well is now the only one used to heat the building. A temperature profile in 1976 showed that the well was almost isothermal at around 92°C.

The well has two 5-cm and one 7.5-cm diameter downhole heat exchangers extending 122 m into the well (Fig. 7). The water level is 10 m below the surface. The maximum flow into the building through the downhole heat exchangers is estimated at 29 L/s and currently at 77°C (it was originally as high as 82°C).



Figure 7. Downhole heat exchangers at Ponderosa Middle School: 2@5-cm and 1@ 7.5-cm diameter feeding into a common header.

The secondary water (city water) from the downhole heat exchanger enters the building mechanical room, assisted by two 5.6 kW circulation pumps, one on the supply line and one on the return line with variable frequency drives. The heated water is then stored in three former oil fired boilers (Fig. 8). From here the water is distributed to the various parts of the building by small circulation pumps. Centralized forced air units are heated with the water and the heated air is then transferred through duct work to the ceilings of the various rooms. All 14 zones and the main circulations pumps are controlled by computers (Fig. 9). In addition, the school is cooled by electric chillers that are integrated with the heat exchangers. Solenoid valves control whether the finned tubed heat exchangers will receive heated or chilled water (Fig. 10). The RC Webview computer system keeps track of the temperature in each classroom and adjusts the pneumatic thermostats for the heat or cooling demand. The computer has an override to keep the rooms from freezing. Domestic hot water is provided at 64°C through a shell-and-tube heat exchanger under one of the boilers (Fig. 8).

The downhole heat exchangers, as is typical in Klamath Falls, corrode (mainly pin-hole corrosion) at the air water interface. Originally, used turbine oil was dumped down the well to coat the pipes at the water level, but, this is no longer allowed. The black iron pipes at the water level have to be replaced about every two years.

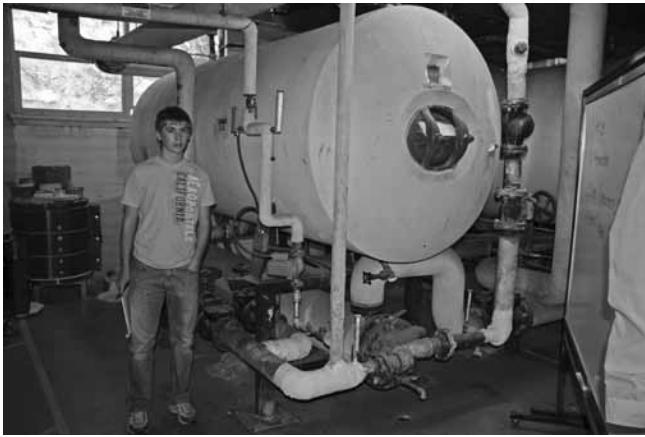

Figure 8. One of the three former oil fired boilers used as a storage tank for the heated secondary water at Ponderosa Middle High School.

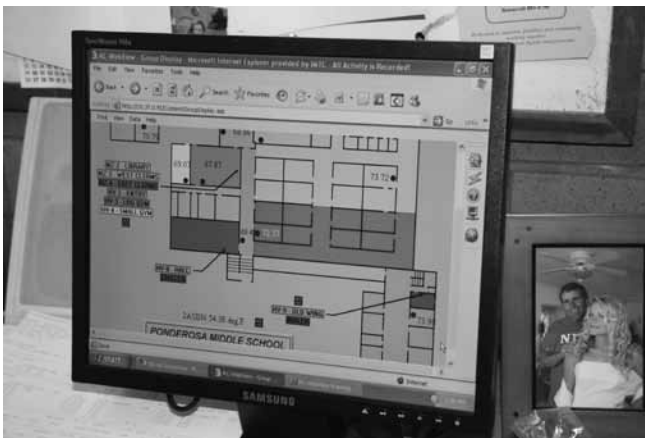

Figure 9. RC Webview computer controlling heat supplied to rooms at Ponderosa Middle School.



Figure 10. Finned tube heat exchangers supplying heated or chilled air to classrooms at Ponderosa Junior High School. Note the solenoid valves at the top of the heat exchanger that can be controlled to supply heated or chilled water.

We estimate that the peak heating load is 2.3 GJ/hr (0.67MWh) and 5.0 TJ/year saving approximately \$69,000 annually in heating cost as compared to natural gas or fuel oil. A schematic of the system is shown in Figure 11.

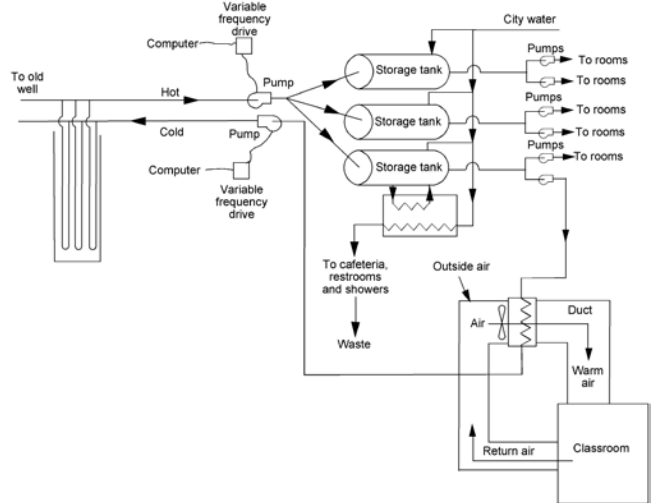

Figure 11. Schematic of the Ponderosa Middle School geothermal heating system.

KLAMATH UNION HIGH SCHOOL

Klamath Union High School is located next to the original “Big Springs” and uses the water from wells in this area for heating the school. The main building was constructed in 1928, the gymnasium (Pelican Court) in 1938, and the south building consisting of the cafeteria and band room in 1958. A separate field house which incorporated the swimming pool for the original Butler’s Natatorium, was built in the early 1940s. The entire complex, except for the field house cover 19,200 m² wings extending to three stories. The geothermal water is pumped directly from a well to the building mechanical room, as the heating load is too large to use downhole heat exchangers. The spent water is returned to an injection well.

Four geothermal wells have been drilled in the field, after the water level from the artesian “Big Springs” dropped below ground level: the 1911 well drilled for the White Pelican Hotel (which burned in 1926) and then later used for the Balsiger Motor Company building, is no longer used; a well drilled in 1940 for the field house and swimming pool, which has since been abandoned; and a production and injection well for the High School. The latter wells were drilled in 1964, the production well to 78m with a temperature of 89°C completed with 32-cm diameter casing to 55 m, and 27-cm diameter casing from 54 to the bottom (Fig. 12). Perforation was provided at 54 and 72 m to the bottom. The water level, now sub-artesian, is approximately 3 m below the surface. The injection well is 73 m deep and 76 m from the production well. The temperature of the injection well varies with the heat load, but is typically 67°C (Culver, 1989). There are other production wells within 150 m in all directions. In theory the system should have cooled down years ago to the point where it was no longer useful for space heating, but it is still in operation. When the system is turned on in the fall, well temperatures fall 3 to 4°C within 7 to 10 days and then remain constant through the heating season. The next fall the production well is back to its original temperature (Culver, 1989).



Figure 12. Klamath Union High School geothermal production well.

A line-shaft turbine pump originally provided 25 L/s at 74°C water to the school mechanical room (6°C is lost between the well and the building), where heat is transferred through two plate heat exchangers, estimated at 2 and 4GJ/hr. Originally several large shell-and-tube heat exchangers were used, but these proved inefficient and difficult to clean. The smaller plate heat exchanger receives heat from the secondary water of the larger heat exchanger and then circulates a glycol-water solution to air pre-heaters for two fresh air intakes. Since only outside air is used, this glycol-water distribution runs all the time so as to prevent the untreated heated secondary water from the main heat exchanger from freezing on cold days. The larger or primary heat exchangers provides heated secondary water to the smaller plate heat exchanger and to two large storage tanks (originally oil-fired boilers) where the temperature of the water can be boosted with natural gas, if necessary (Fig. 13 and 14).

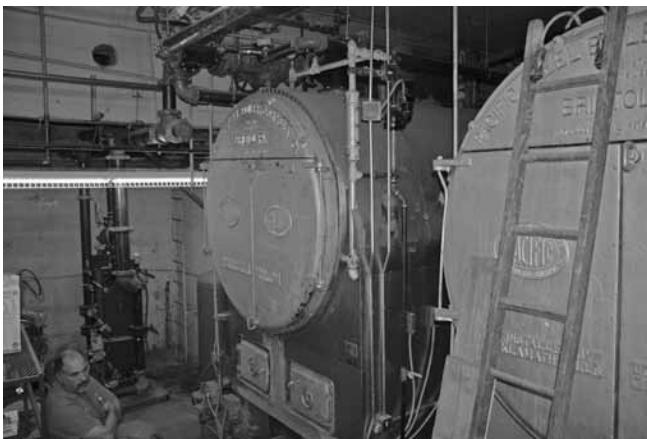

Figure 13. Main plate heat exchanger and hot water boilers for Klamath Union High School.

The secondary water heats two main finned coiled forced air units in two smaller mechanical rooms along with numerous hot water heaters and other smaller forced air units that provide heated air through vents in the classroom walls. The field house is heated by water by the return water from the main building through radiant floor pipes and hot water radiators before being injected in the second well. The

secondary water also melts snow on two entrance steps. There were other snow melt systems, but these have been shut down due to failures in the pipes. A bridge deck approaching the school was recently retrofitted for snow melting using geothermal energy from the city district heating system (Boyd, 2003). A small enclosed parking lot where it is difficult to remove and stockpile the snow, uses the secondary water directly by spraying to melt the snow. The water has also been used to melt heavy snow loads on the Pelican Court roof, and a permanent roof snow melt system is being considered. A third plate heat exchanger provides domestic hot water to the building.

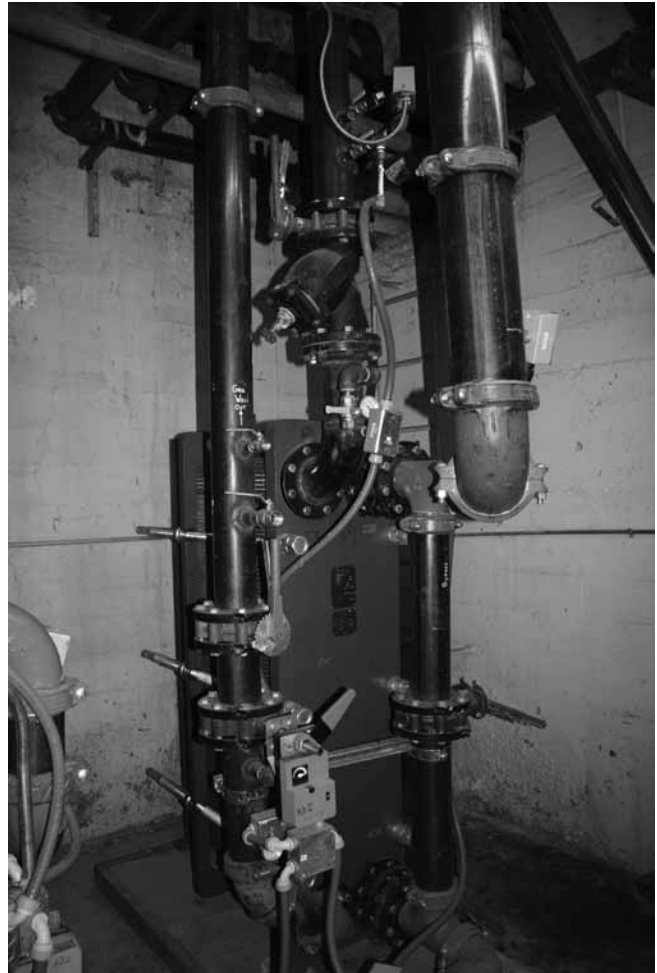

Figure 14. Detail of the main plate heat exchanger at Klamath Union High School.

Scaling deposits on the main plate heat exchangers have reduced the efficiency of the heat transfer and thus have to be cleaned or replaced periodically. Recently, the geothermal water has cooled and has been entering the main plate heat exchanger at 54°C and leaving at 41°C, into the smaller heat exchanger at 43°C and out at 38°C, and into the boilers at 48°C and out at 44°C.

It is estimated that 3.3 GJ/hr (1.0 MWth) of peak heat and 7.2 TJ/yr geothermal energy is used. This provides a savings of approximately \$100,000 annually.

CONCLUSIONS

The three local schools that the author (Thomas) has attended have been using geothermal water for heat for over 50 years. They tap into the geothermal water upwelling along a high angle normal fault – part of the Basin and Range geologic system – along the east side of the City of Klamath Falls. The water is around 90°C and either uses downhole heat exchanger to extract the heat from the well water (Roosevelt Elementary School and Ponderosa Middle School), or pumps the water directly into the building and then sends the waste geothermal water to an injection well (Klamath Union High School). All the wells are fairly shallow, at less than 200 m deep and are sub-artesian. The estimate peak energy use of the three schools is 6.8 GJ/hr (2.02 MWth) with an annual energy use of 14.9 TJ. The estimated annual savings is \$206,000 as compared to using natural gas.

ACKNOWLEDGMENTS

We would like to thank Paul Carney, maintenance supervisor at Roosevelt Elementary School; Del Horton, maintenance supervisor at Ponderosa Middle School, and John Kellum and Ron Bryant, maintenance supervisors at Klamath Union High School for providing a time to visit the school and explaining how their geothermal heating system operated.

REFERENCES

- Boyd, T. L.: “New Snow Melt Projects in Klamath Falls, OR,” *Geo-Heat Center Quarterly Bulletin*, Vol. 24, No. 3, pp. 12-15, Klamath Falls, OR, (2003)
- Brown, B.: “Klamath Falls Geothermal District Heating System at 25 Years”, *Geo-Heat Center Quarterly Bulletin*, Vol. 28, No. 1, pp. 10-15, Klamath Falls, OR, (2007).
- Culver, G.: “Direct Use Injection Wells”, *Geo-Heat Center Quarterly Bulletin*, Vol. 11, No. 4, pp. 1-5, Klamath Falls, OR, (1989).
- Culver, G. and J. W. Lund: “Downhole Heat Exchangers,” *Geo-Heat Center Quarterly Bulletin*, Vol. 20, No. 3, pp. 1-11, Klamath Falls, OR, (1999).
- Fornes, A.: “Charlie Leib – Veteran of Geothermal Development,” *Geo-Heat Center Quarterly Bulletin*, Vol. 6, No. 1, pp. 10-13, Klamath Falls, (1981).
- Lund, J. W.: “Big Springs.” *Geo-Heat Center Quarterly Bulletin*, Vol. 3, No. 3, pp. 7-13, Klamath Falls, OR, (1978)
- Lund, J. W., Culver, G. G. and L. S. Svanevik: “Utilization of Geothermal Energy in Klamath Falls.” *Proceedings, Multipurpose Use of Geothermal Energy, Oregon Institute of Technology*, pp. 146-178, Klamath Falls, OR, (1974)
- Lund, J. W., Culver, G., and P. J. Lienau: *Groundwater Characteristics and Corrosion Problems Associated with the Use of Geothermal Water in Klamath Falls, Oregon*, Geo-Heat Center, Klamath Falls, OR, (1976).
- Lund, J. W., and T. Boyd: “Oregon Institute of Technology Geothermal Uses and Projects – Past, Present and Future,” *Proceedings, 34th Workshop on Geothermal Reservoir Engineering*, Sanford University, (2009)